

The lightning flash with an arrowhead symbol, within an equilateral triangle is intended to alert the user to the presence of uninsulated dangerous voltage within the product's enclosure that may be of sufficient magnitude to constitute a risk of electric shock to persons.



The exclamation point within an equilateral triangle is intended to alert the user to the presence of important operating and maintenance (servicing) instructions in the literature accompanying the appliance.

**INFORMATION** - This equipment has been tested and found to comply with limits for a Class A digital device, pursuant to part 15 of the FCC Rules & CE Rules. These limits are designed to provide reasonable protection against harmful interference when the equipment is operated in a commercial environment. This equipment generates, uses, and can radiate radio frequency energy and, if not installed and used in accordance with the instruction manual, may cause harmful interference to radio communications. Operation of this equipment in a residential area is likely to cause harmful interference in which case the user will be required to correct the interference at his own expense.

**WARNING** - Changes or modifications not expressly approved by the manufacturer could void the user's authority to operate the equipment.

**CAUTION** : To prevent electric shock and risk of fire hazards:

- ◆ Do NOT use power sources other than those specified.
- ◆ Do NOT expose this appliance to rain or moisture.

This installation should be made by a qualified service person and should conform to all local codes.

## ■ Contents

<b>Components</b>	2
<b>Features</b>	4
<b>Warnings and Precautions</b>	5
<b>Names and Functions of Parts</b>	9
■ Lens	10
■ OSD	10
■ VBS-EXTRA	11
■ SMPS	11
■ 3 Axis Bracket	11
<b>Dimensions</b>	11
<b>Installation</b>	12
<b>Cable Connections</b>	12
<b>Installation</b>	14

<b>Menu Flow</b>	15
■ Setup Page Menu	18
• PRESETS	18
• LENS	19
• WDR	19
• WHITE BALANCE	20
• AGC (Auto Gain Control)	21
• DNR (Digital Noise Reduction)	21
• SENS-UP	22
• EXIT	22
■ Special Page Menu	23
• CAMERA ID	23
• DAY & NIGHT	24
• FLIP	24
• DZOOM	25
• MOTION	25
• PRIVACY MASK SETUP	26
■ Advanced Page Menu	27
• VIDEO STANDARD	27
• RESOLUTION	27
• BACKLIGHT	28
• SYNC	28
• SHARPNESS	29
• APERTURE	29
• RS485 SETUP	30
<b>Troubleshooting</b>	31
<b>Specifications</b>	33

## ■ Features

### High Resolution color for crisp, clear video

- 540TV Line(Color) : High resolution mode
- 580TV Line(B/W) : High resolution mode

### Wide Dynamic Range (WDR)

The camera delivers clear, high quality pictures even in backlight, by increasing exposure in dark areas while decreasing it in bright areas; a corrected image with clear details results.

- 120dB maximum dynamic range

### Filter Changeable Day & Night

This camera has a function that automatically selects the mode that is appropriate for daytime or night-time conditions. The COLOR mode operates in daytime conditions to provide optimum colors and BW mode operates in nighttime conditions to enhance the definition of the image.

### High Sensitivity for low-light images

The built-in high sensitivity PIXIM BELUGA C-MOS enables a clear image

- Color : 0.5Lux
- B/W : 0.08Lux

### DNR (Digital Noise Reduction)

The amount of low illuminance noise has been significantly reduced, and the signal-to-noise ratio (S/N ratio) as well as horizontal resolution have been improved, resulting in a clear and sharp image display even in the dark.

### Additional Functions

- Automatic White Balance
- Backlight Compensation
- Automatic Gain Control
- Motion Detection
- Digital Zoom (x4)
- Privacy Mask (12 Zone)

### RS-485 Communication Control Support

Remote OSD menu control via an RS-485 interface is supported.

### Controlled by OSD Menu

- The camera can be controlled by selecting text displayed on the monitor screen.

### 3 Axis built-in 100mm Dome Housing

## Warning ■

### The camera requires periodic inspection.

Contact an authorized technician to carry out the inspection.

### Stop using your camera when you find it malfunctioning.

If the camera emits smoke or is unusually hot for a long period, a fire may be caused.

### Do not install the camera on a surface that can not support it.

If the camera is installed on an inappropriate surface, it may fall and cause injury.

### Do not hold plug with wet hands.

It could cause an electric shock.

### Do not dis-assemble the camera.

It may result in an electric shock or other hazards.

### Do not use the camera close to a gas or oil leak.

It may result in a fire or other hazards.

## ■ Precautions

**Do not install the camera in extreme temperature conditions.**



Only use the camera under conditions where temperatures are between  $-10^{\circ}\text{C}$  and  $+50^{\circ}\text{C}$ . Be especially careful to provide ventilation when operating under high temperatures.

**Do not install or use the camera in an environment where the humidity is high.**



It can cause the image quality to be poor.

**Do not install the camera under unstable lighting conditions.**

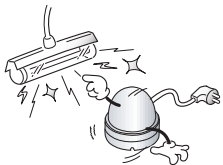

Severe lighting change or flicker can cause the camera to work improperly.

**Do not touch the front lens of the camera.**



This is one of the most important parts of the camera. Be careful not to leave fingerprints on the lens cover.

**Do not drop the camera or protect it from physical shocks.**



It can cause malfunctions to occur.

**Never keep the camera pointed directly at strong light.**

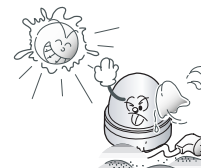

It can damage the CCD.

**Do not expose the camera to rain or spill beverage on it.**



If it gets wet, wipe it dry immediately. Liquids can contain minerals that corrode the electronic components.

**Do not expose the camera to radioactivity.**



If exposed to radioactivity the CCD will fail.



### Note

¥If the camera is exposed to spotlight or object reflecting strong light, smear or blooming may occur.

¥Please check that the power satisfies the normal specification before connecting the camera.

## ■ Components

1. COLOR DOME CAMERA .....

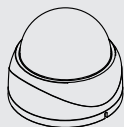

2. SCREWS .....



3. WIRE FOR VBS-EXTRA .....



4. INSTRUCTION GUIDE .....



## Names and Functions of Parts ■

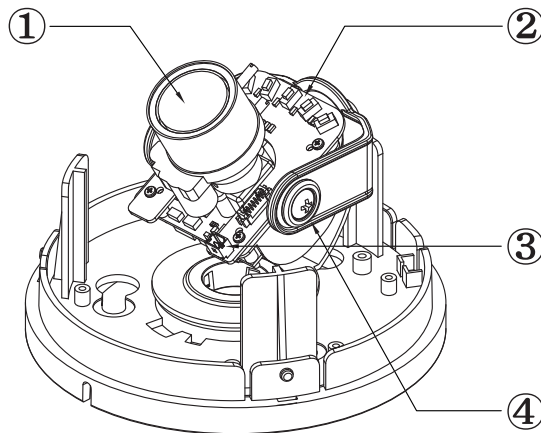

## Names and Functions of Parts

### ① LENS : Vari-Focal DC Auto Iris Lens

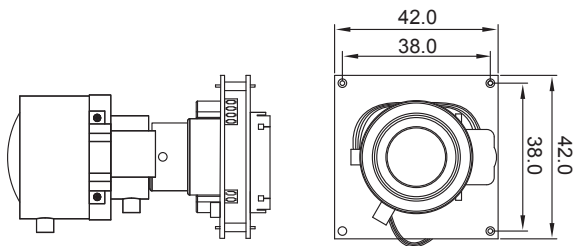

### ② OSD PCB

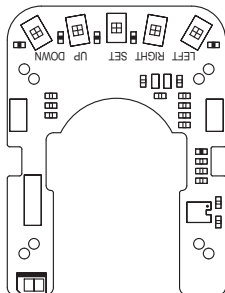

- **SET button** : Used for the menu display. This button can be used to confirm settings after changing the value of the selected function or current conditions.
- **UP & DOWN buttons** : Used for selecting items by moving the cursor up or down on the menu screen.
- **LEFT & RIGHT buttons** : Used when changing item values, by moving the cursor to the left or right on the menu screen.

## Names and Functions of Parts

### ③ VBS-EXTRA FOR CONNECTING TO LCD

Please use the supplied wire when connecting to external monitor

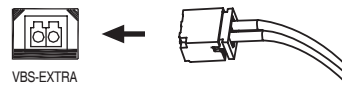

### ④ 3 AXIS BRACKET

Adjust the pan and tilt to give the correct angle of view.

## Dimensions

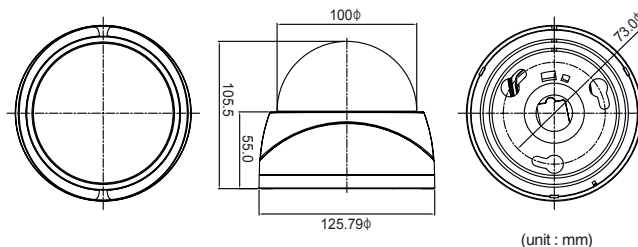

## ■ Installation

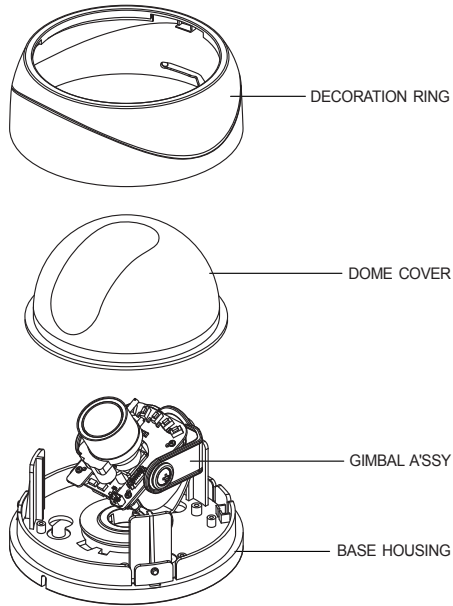

## ■ Cable Connections

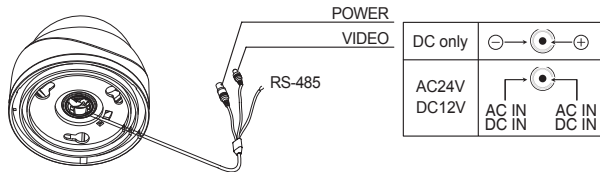

### 1. Dome Base Mounting

- Open the dome cover by loosening 3 screws using special wrench provided.
- Mount the base of camera to a sturdy surface using 4 screws (1.5 inch) and 4 premade holes on the base of the dome.

### 2. Power Connect & Monitor Impedance

- DC12V/300mA regulated power supply (DC12V only)
- AC24V Class 2 power supply (AC24V/DC12V)
- To avoid fire or shock hazard, must use a UL listed power supply.
- Set the monitor impedance switch to 75Ω. Check the impedance switch when the screen turns blurred.

### 3. Camera Module Adjustment

- Loosen screws for 3-axis camera bracket and adjust the direction and angle of camera.
- Make sure to retighten the screws for camera bracket.
- Set any function you wish to activate by using the OSD buttons.

### 4. Dome Cover Mounting

- Replace the dome cover to the base and tighten 3 screws.

## Control via RS-485 Interface

The camera can be controlled by using external controllers like a Remote controller. (RS-485 Communication)

- To control using a DVR or System Controller  
Connect the RS-485 cable (TRX+, TRX-) to the connection port of the 485 control board that is connected to the DVR or System Controller.

485 Control Board Connection Port	RS-485 Control Port
(+) CONNECTION TERMINAL (TRX+)	485+
(-) CONNECTION TERMINAL (TRX-)	485-

### Note

- To control the camera by constructing an additional controller, use Pelco-D protocol.  
(Go Preset 95 : Enters into OSD menu or Set key function)

## Installation

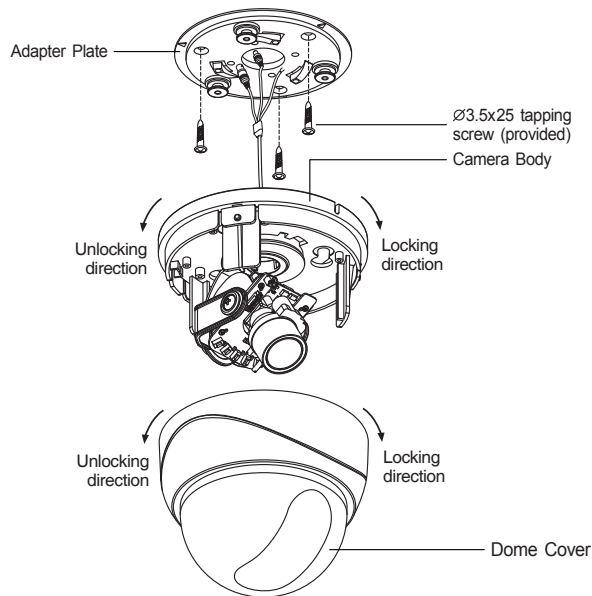

### \* When installing on an adapter plate bracket.

- ① Place the adapter plate bracket on a flat installation surface and fix it with the screws provided.
- ② When placing the camera body onto the plate, insert the plate pin into the corresponding holes on the camera body as shown in figure-1. Lock the camera in place by turning the camera body clockwise.
- ③ When placing the camera body on the plate, make sure that the power and video cables pass through.
- ④ After installation and adjustment of the camera is complete, secure the dome cover by turning it clockwise.

## Menu Flow

### Setup Page Menu

SETUP	
▶ PRESETS	WD NORMAL NORMAL INDOOR OUTDOOR FLUOR1.. FLUOR2..
LENS	DC.. VIDEO.. MANUAL
WDR	AUTO HIGH USER.. LOW BIAS, LIMIT
WHITE BAL.	ATW.. ATWDes.. AWC.. MANUAL.. RED, BLUE
AGC	MIDDLE HIGH OFF LOW
DNR	AUTO OFF
SENS-UP	AUTO.. OFF
SPECIAL..	
EXIT	

Special Page Menu

SPECIAL

- ▶ CAMERA ID OFF  
ON.. ID, Position
- DAY&NIGHT AUTO..  
BW  
COLOR
- FLIP OFF  
HORIZ  
VERT  
BOTH
- DZOOM OFF  
ON..
- MOTION OFF  
ON..
- PRIVACY MASK SETUP ...  
PRIVACY MASK  
MASK COLOR
- ADVANCED SETUP..
- RESET
- RETURN

Advanced Page Menu

ADVANCED SETUP

- ▶ VIDEO STANDARD NTSC..  
PAL..
- RESOLUTION HIGH  
NORMAL
- BACKLIGHT OFF  
ON..
- SYNC INT  
LL..
- SHARPNESS -8 ----- 8
- APERTURE -8 ----- 8
- RS485 SETUP
- VERSION (D25\_4.3H.DD)
- RETURN

## Setup Page Menu

### PRESETS

SETUP

► PRESETS    WD NORMAL

NORMAL

INDOOR

OUTDOOR

FLUOR1..

FLUOR2..

LENS            DC

WDR            AUTO

WHITE BAL.    ATW

AGC            MIDDLE

DNR            AUTO

SENS-UP        AUTO

SPECIAL

EXIT

• WD Normal : WD Normal environment.

WD NORMAL PRESET

> RETURN

H-Extra High/Shutter Pri

Preference = Highlights

Max DR = 17 bits

• Normal : Normal environment.

NORMAL PRESET (ONE)

> RETURN

H-Normal/Shutter Pri

Preference = Highlights

Max DR = 14 bits

• Indoor : Indoor environment.

INDOOR PRESET (TWO)

> RETURN

S-Normal/Shutter Pri

Preference = Shadows

Max DR = 16 bits

• Outdoor : Outdoor environment.

OUTDOOR PRESET (THREE)

> RETURN

H-High / Shutter Pri

Preference = Highlights

Max DR = 17 bits

• FLUOR1 : Fluor1 environment.

FLUORESCENT 1 PRESET

> RETURN.

FLUORESCENT 1

Preference = Highlights

\*Line Lock Recommended\*

• FLUOR2 : Fluor2 environment.

FLUORESCENT 2 PRESET

> RETURN.

FLUORESCENT 2

Preference = Shadows

\*DC Iris Only\*

## Setup Page Menu

### LENS

SETUP

PRESETS            WD NORMAL

► LENS              DC

VIDEO

MANUAL

WDR                AUTO

WHITE BAL.        ATW

AGC                MIDDLE

DNR                AUTO

SENS-UP            AUTO

SPECIAL

EXIT

• LENS

Choose the lens type DC, Video and Manual lens by using the selector button.

DC MODE

► BIAS              0    120    255

LIMIT              -42   -18    60

PREVIOUS PAGE

### WDR

Wide Dynamic Range is essential for capturing the images at all light levels. The main function of the WDR is to accumulate the scope of contrast between the brightest and darkest points in the picture. With the AUTO option, the distribution of brightness values is automatically adapted to the recording scenario.

SETUP

PRESETS            WD NORMAL

LENS                DC

► WDR              USER

AUTO

HIGH

LOW

WHITE BAL.        ATW

AGC                MIDDLE

DNR                AUTO

SENS-UP            AUTO

SPECIAL

EXIT

• User can select the desired level HIGH, USER & LOW, in addition to automatic adaptation (Auto), by moving the selector button.

WDR LEVEL

► BIAS              0    -36    36

LIMIT              36    0    36

PREVIOUS PAGE

## ■ Setup Page Menu

### WHITE BALANCE

White Balance is a function which compensates different colors of light being emitted from different light sources.

Users can select the above levels as they desire according to the environment.

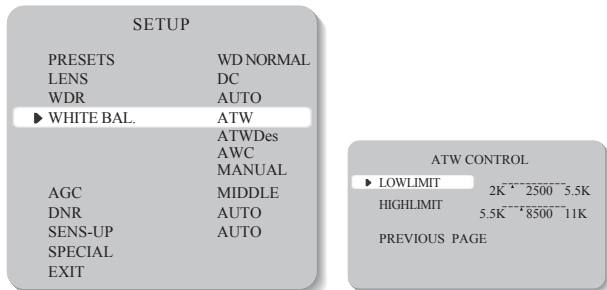

- **ATW (Auto Tracking White Balance)**

The ATW mode continuously monitors color temperature. With WB Control set to ATW, color temperature & White balance can be automatically adjusted accordingly.

- **ATWDesat (ATW Desaturating)**

When WB is set to ATWDesat, the Extended Color temperature is desaturated i.e when there is a excess of light temperature, ATWDesat Function is used as well as it reduces the Noise. The limits of the color temperature setting remain 2000K and 11,000K

- **AWC (Auto White Balance)**

When set to AWC, Color temperature of the Light is automatically adjusted.

- **Manual (Manual White Balance)**

Manual White Balance (MWB) Mode is used when other White Balance Options are failed.

## Setup Page Menu ■

### AGC

Automatic Gain Control is a feature which adjust automatically according to the incoming Signal. By positioning the arrow to 'AGC' on the SETUP menu with the help of UP and DOWN buttons, you can select the Mode you wish to go

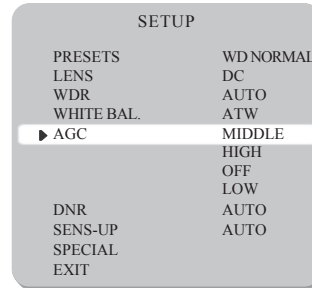

- As the level of gain increases, the screen gets brighter and the level of noise also increases.

### DNR

DNR is Digital Noise Reduction System with a maximum gain of 24 DB.

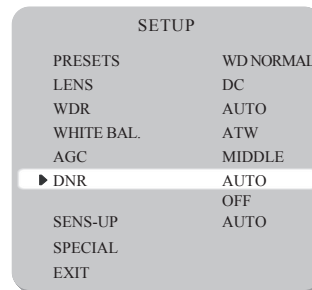

- **AUTO**  
There is a reduction in noise level with almost no ghost image.
- **OFF**  
There is no reduction in noise level.

## ■ Setup Page Menu

### SENS-UP

Sens-up helps maintain a bright, clear screen image by automatically detecting changes in the level of light in low light level conditions.

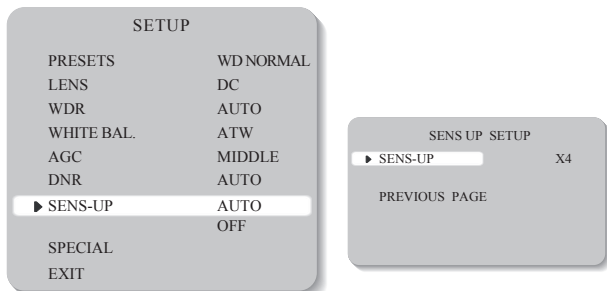

- Position the arrow to point to 'SENS UP' on the SETUP menu by using the UP and DOWN buttons.
- Select the value required by pressing the LEFT or RIGHT button.
  - **AUTO** : Low light level automatic mode. (X2~X32)
  - **OFF** : The function does not operate.
- Press the SET button when all the settings are complete.

### EXIT

Saves all the setting menus and then exits.

## ■ Special Page Menu

### CAMERA ID

User can enter a unique name for the respective camera.  
The maximum length of the ID is ten characters.

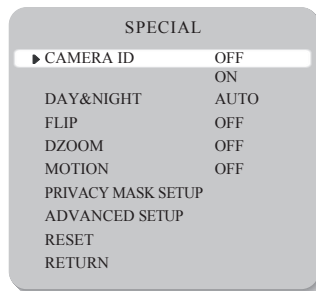

- You can choose the ON and OFF with the selector. If you select ON, the entered camera ID is displayed at the selected position in the video picture (normal operation).
- Please select the setup button while in ON mode.
- Select the desired position with the selector.

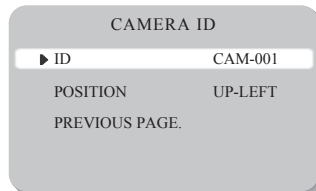

- ① Move the cursor to the letter required by using the Set-Up button.
- ② Select an ID from A,B~Y,Z, a,b~y,z 0,1~8,9 by using the LEFT and RIGHT buttons.
- ③ Repeat the above steps until the ID is complete.

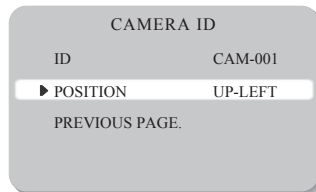

- ① Select the position where the ID is to be displayed by using the LEFT and RIGHT buttons.

## Special Page Menu

### DAY & NIGHT

This camera has a function that automatically selects the mode that is appropriate for daytime or night-time conditions. The COLOR mode operates in daytime conditions to provide optimum colors, and BW mode operates in nighttime conditions to enhance the definition of the image.

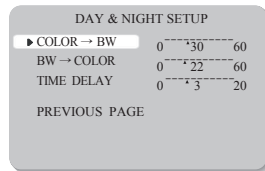
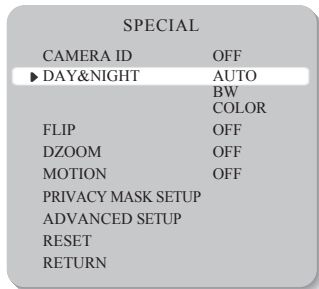

### FLIP

Select "OFF" to show the image as normal. Select "ON" to reflect image horizontally.

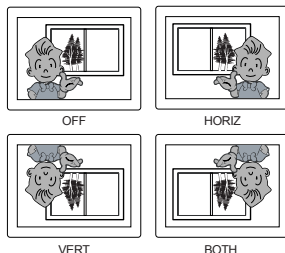
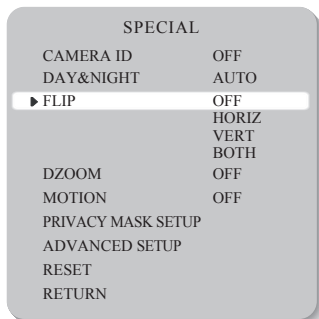

## Special Page Menu

### DZOOM

Digital P/T/Z are used to create a zoom lens effect. Zoom Factor (1X to 4X) Pan ( $\pm 100\%$ , center of image can be moved to left and right edges of screen) Tilt ( $\pm 100\%$ , center of image can be moved to top and bottom edges of screen)

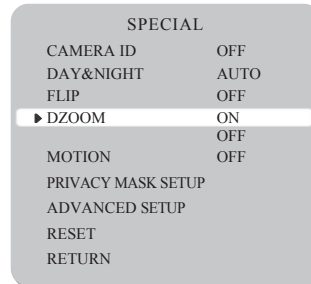

- By Selecting ON, DZoom is enabled.
- By Selecting OFF, DZoom is disabled.

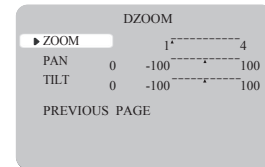

### MOTION

This product has a feature that allows you to observe movements of objects in on the screen, hence a single individual can conduct supervision efficiently. The camera detects an object's movement by sensing disparity of outline, and level of brightness and color.

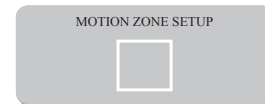
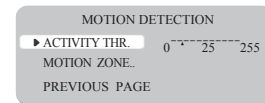
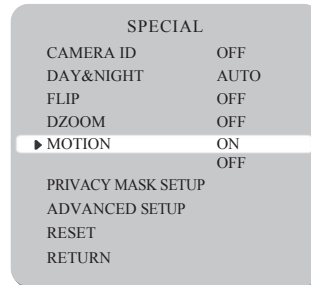

- White : MOTION ZONE Position movement
- Green : MOTION ZONE Size enlargement
- Red : MOTION ZONE Size reduction
- For MOTION ZONE Confirm, long press SET button

## Special Page Menu

### PRIVACY MASK SETUP

Hide an area you want to hide on the screen.

SPECIAL

CAMERA ID	OFF
DAY&NIGHT	AUTO
FLIP	OFF
DZOOM	OFF
MOTION	OFF
▶ PRIVACY MASK SETUP	
ADVANCED SETUP	
RESET	
RETURN	

PRIVACY MASK SETUP

▶ PRIVACY MASK	OFF
MASK COLOR	WHITE
PREVIOUS PAGE.	

ENABLE MASKS (1 to 6)

▶ MASK 1	ON
MASK 2	OFF
MASK 3	OFF
MASK 4	OFF
MASK 5	OFF
MASK 6	OFF
PREVIOUS.	NEXT.

ENABLE MASKS (7 to 12)

▶ MASK 7	OFF
MASK 8	OFF
MASK 9	OFF
MASK 10	OFF
MASK 11	OFF
MASK 12	OFF
PREVIOUS.	

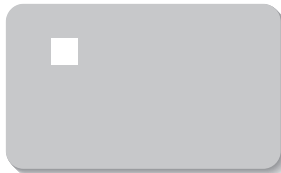

- White : PRIVACY-ZONE Position movement
- Blue : PRIVACY-ZONE Size enlargement or reduction
- For PRIVACY-ZONE Confirm, long press SET button

## Advanced Page Menu

### VIDEO STANDARD

Choose video system between PAL and NTSC by moving the selector.

ADVANCED SETUP

▶ VIDEO STANDARD	NTSC
RESOLUTION	HIGH
BACKLIGHT	OFF
SYNC	INT
SHARPNESS	-8-----8
APERTURE	-8-----8
RS485 SETUP	
VERSION (D25_4.3H.DD)	
RETURN	

NTSC

▶ SETUP	ON
VIDEO LEVEL	80 110 150
SYNC LVL	0 -16-----15
BURST LVL	0 -16-----15
COLOR BAR	OFF
PREVIOUS PAGE.	

PAL

▶ VIDEO LEVEL	80 110 150
SYNC LVL	0 -16-----15
BURST LVL	0 -16-----15
COLOR BAR	OFF
PREVIOUS PAGE.	

### RESOLUTION

Choose resolution between high and normal with the selector (RIGHT/LEFT)

ADVANCED SETUP

VIDEO STANDARD	NTSC
▶ RESOLUTION	HIGH
	NORMAL
BACKLIGHT	OFF
SYNC	INT
SHARPNESS	-8-----8
APERTURE	-8-----8
RS485 SETUP	
VERSION (D25_4.3H.DD)	
RETURN	

- The high resolution supports Progressive Rate video up to 540 TV Line and normal resolution supports 480 TV Line.

## Advanced Page Menu

### BACKLIGHT

Backlight is feature of a Camera which compensates when there is a large amount of background light.

#### ADVANCED SETUP

VIDEO STANDARD	NTSC
RESOLUTION	HIGH
▶ BACKLIGHT	OFF
	ON
SYNC	INT
SHARPNESS	-8-----8
APERTURE	-8-----8
RS485 SETUP	
VERSION (D25_4.3H.DD)	
RETURN	

- When Backlight is ON, Back Light gets activated.

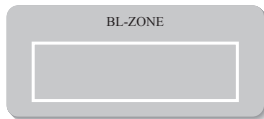

- White : BL-ZONE Position movement
- Green : BL-ZONE Size enlargement
- Red : BL-ZONE Size reduction
- For BL-ZONE Confirm, long press SET button

### SYNC

Two synchronization modes are available, INTERNAL and EXTERNAL LINE-LOCK. In LINE-LOCK mode, it synchronizes the video signal between cameras without a synchronous generator. The line-lock synchronization is only used in areas of 60Hz (NTSC) / 50Hz (PAL).

#### ADVANCED SETUP

VIDEO STANDARD	NTSC
RESOLUTION	HIGH
BACKLIGHT	OFF
▶ SYNC	INT
	LL
SHARPNESS	-8-----8
APERTURE	-8-----8
RS485 SETUP	
VERSION (D25_4.3H.DD)	
RETURN	

- INT : Internal synchronization
- LL : External line-lock synchronization
- If 'LL' is selected, it can be adjusted to the desired phase. Press the SET button.
- Adjust to the desired phase from 0 to 624.

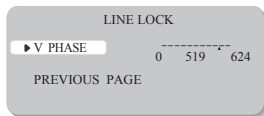

## Advanced Page Menu

### SHARPNESS

The outline of the video image becomes cleaner and more distinctive as the level of SHARPNESS increases. If the level goes up excessively, however, it may affect the video image and generate noise.

#### ADVANCED SETUP

VIDEO STANDARD	NTSC
RESOLUTION	HIGH
BACKLIGHT	OFF
SYNC	INT
▶ SHARPNESS	-8-----8
APERTURE	-8-----8
RS485 SETUP	
VERSION (D25_4.3H.DD)	
RETURN	

- The available range of level is -8 ~ 8

### APERTURE

The outline of the video image becomes cleaner and more distinctive as the level of APERTURE increases. If the level goes up excessively, however, it may affect the video image and generate noise.

#### ADVANCED SETUP

VIDEO STANDARD	NTSC
RESOLUTION	HIGH
BACKLIGHT	OFF
SYNC	INT
SHARPNESS	-8-----8
▶ APERTURE	-8-----8
RS485 SETUP	
VERSION (D25_4.3H.DD)	
RETURN	

- The available range of level is -8 ~ 8

## Advanced Page Menu

### RS485 SETUP

This function sets up the camera communication status when controlling the camera through an external control device.

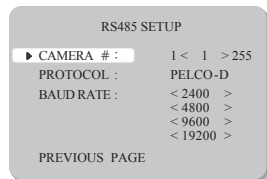
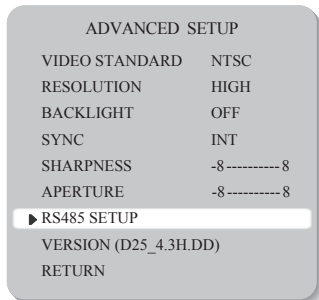

## Troubleshooting

If you have trouble operating your camera, refer to the following table. If the guidelines do not enable you to solve the problem, contact an authorized technician.

Problem	Solution
<b>Nothing appears on the screen.</b>	<ul style="list-style-type: none"> <li>• Check the power connections.</li> <li>• Check the VIDEO signal line connection.</li> </ul>
<b>The image on the screen is dim.</b>	<ul style="list-style-type: none"> <li>• Make sure the lens is clean. Clean the lens with a soft clean lint free cloth.</li> <li>• Adjust the monitor contrast &amp; brightness controls.</li> <li>• Re-position the camera if necessary.</li> </ul>
<b>The image on the screen is dark.</b>	<ul style="list-style-type: none"> <li>• Adjust the contrast control of the monitor.</li> <li>• If you have an intermediate device, set the 75Ω/ Hi-Z property.</li> </ul>
<b>The camera is not working properly, and the surface of the camera is hot.</b>	<ul style="list-style-type: none"> <li>• Check that an appropriate power source is connected to the camera.</li> </ul>
<b>The DAY/NIGHT menu does not work.</b>	<ul style="list-style-type: none"> <li>• Check that AGC in the EXPOSURE menu is set to 'OFF'.</li> </ul>
<b>The SENS-UP function does not work.</b>	<ul style="list-style-type: none"> <li>• Check that AGC in the EXPOSURE menu is not set to 'OFF'.</li> <li>• Check that SHUTTER in the EXPOSURE menu is not set to 'FLK' or 'MANUAL'.</li> </ul>

## ■ Troubleshooting

Problem	Solution												
<b>The Motion Detection function does not work.</b>	<ul style="list-style-type: none"> <li>Check that MOTION DET in the SPECIAL SETUP is not set to 'OFF'.</li> </ul>												
<b>Color is not correct.</b>	<ul style="list-style-type: none"> <li>Check the WHITE BAL settings in the SETUP menu.</li> </ul>												
<b>The screen flickers continually.</b>	<ul style="list-style-type: none"> <li>Check that the camera is not facing toward the sun.</li> </ul>												
<b>RS-485 communication fails.</b>	<ul style="list-style-type: none"> <li>Check the polarity between the RS-485 Control Port and the RS-485 cable. <table border="1" data-bbox="347 497 711 553"> <thead> <tr> <th>485 Control Board Connection Port</th> <th>RS-485 Control Port</th> </tr> </thead> <tbody> <tr> <td>(+) CONNECTION TERMINAL (TRX+)</td> <td>485+</td> </tr> <tr> <td>(-) CONNECTION TERMINAL (TRX-)</td> <td>485-</td> </tr> </tbody> </table> </li> <li>Check the RS-485 Communication default settings. <p>* RS-485 Communication default settings are:</p> <table border="1" data-bbox="347 639 711 676"> <thead> <tr> <th>Item</th> <th>Camera ID</th> <th>BAUD RATE</th> </tr> </thead> <tbody> <tr> <td>Initial value</td> <td>1</td> <td>2400</td> </tr> </tbody> </table> </li> </ul>	485 Control Board Connection Port	RS-485 Control Port	(+) CONNECTION TERMINAL (TRX+)	485+	(-) CONNECTION TERMINAL (TRX-)	485-	Item	Camera ID	BAUD RATE	Initial value	1	2400
485 Control Board Connection Port	RS-485 Control Port												
(+) CONNECTION TERMINAL (TRX+)	485+												
(-) CONNECTION TERMINAL (TRX-)	485-												
Item	Camera ID	BAUD RATE											
Initial value	1	2400											

## Specifications ■

ITEM	Specifications
<b>Image Sensor</b>	PIXIM 1/3" C-MOS BELUGA Sensor
<b>Effective Pixels</b>	720(H) x 540(V)
<b>Sync System</b>	INT / LL Selectable
<b>Electronic Shutter</b>	up to 1/22,000sec.
<b>Main Video Output</b>	1.0 Vp-p Composite, 75 ohm
<b>Service Monitor Output</b>	1.0 Vp-p Composite, 75 ohm
<b>Horizontal Resolution</b>	540TV Lines (Color), 580TV Line (B/W) : High resolution mode
<b>Min. Illumination</b>	0.5Lux (Color), 0.08Lux (B/W)
<b>Dynamic Range</b>	120dB (max), 102dB (typical)
<b>AGC Control</b>	0~46dB
<b>DNR</b>	OFF / AUTO <input type="checkbox"/>
<b>Lens</b>	Vari-Focal DC Auto Iris Lens
<b>Camera Control&amp;Setup</b>	OSD Menu
<b>Power Consumption</b>	DC12V Only (Max.220mA) AC24V / DC12V Dual Voltage (Max.240mA / 360mA)
<b>Operating Temperature</b>	-10℃ ~ +50℃
<b>Operating Humidity</b>	Within 90% RH
<b>Weight</b>	350g

■ MEMO



**Modle : HTC-16GWD28D**

# **WDR True Day&Night Dome Camera**

**Instruction Guide**

---

**Modle : HTC-16GWD28D**  
**WDR True Day&Night Dome Camera**

---

Printed in KOREA