

HTP-T3700

H.264 IP Speed Dome Camera



Camera Manual Ver. 1.0





CAUTION
RISK OF ELECTRIC
SHOCK DO NOT OPEN



**CAUTION : TO REDUCE THE RISK OF ELECTRICAL SHOCK, DO NOT OPEN COVERS.
NO USER SERVICEABLE PARTS INSIDE.
REFER SERVICING TO QUALIFIED SERVICE PERSONAL.**



This lightning flash with arrowhead symbol is intended to alert the user to the presence of un-insulated "dangerous voltage" within the product's enclosure that may be of sufficient magnitude to constitute a risk of electric shock to persons.



This exclamation point symbol is intended to alert the user to the presence of important operating and maintenance (servicing) instructions in the literature accompanying the appliance.

**WARNING : TO PREVENT THE RISK OF FIRE OR ELECTRIC SHOCK HAZARD, DO NOT EXPOSE
THIS CAMERA TO RAIN OR MOISTURE.**



Important Safeguard

1. Read Instructions

Read all of the safety and operating instructions before using the product.

2. Retain Instructions

Save these instructions for future reference.

3. Attachments / Accessories

Do not use attachments or accessories unless recommended by the appliance manufacturer as they may cause hazards, damage product and void warranty.

4. Installation

Do not place or mount this product in or on an unstable or improperly supported location. Improperly installed product may fall, causing serious injury to a child or adult, and damage to the product. Use only with a mounting device recommended by the manufacturer, or sold with the product. To insure proper mounting, follow the manufacturer's instructions and use only mounting accessories recommended by manufacturer.

5. Power source

This product should be operated only from the type of power source indicated on the marking label.

Precautions

Operating

- Before using, make sure power supply and others are properly connected.
- While operating, if any abnormal condition or malfunction is observed, stop using the camera immediately and then contact your local dealer.

Handling

- Do not disassemble or tamper with parts inside the camera.
- Do not drop or subject the camera to shock and vibration as this can damage camera.
- Care must be taken when you clean the clear dome cover. Especially, scratch and dust will ruin your quality of camera.

Installation and Storage

- Do not install the camera in areas of extreme temperature, which exceed the allowable range.
- Avoid installing in humid or dusty places.
- Avoid installing in places where radiation is present.
- Avoid installing in places where there are strong magnetic fields and electric signals.
- Avoid installing in places where the camera would be subject to strong vibrations.



① Introduction	
Features	5
Product & Accessories	7
Parts Name & Functions	8
② Installation	
DIP Switch Setup	9
Installation using Wall Mount Bracket	12
Installation using Ceiling Mount Bracket	13
Cabling	15
③ Operation	
Checking Before Operation	17
Preset and Pattern Function Pre-Check	17
Start OSD Menu	18
Reserved Preset	18
Preset	19
Swing	19
Pattern	20
Group	21
Other Motion Functions	22
OSD Display of Main Screen	23
④ How to use OSD Menu	
General Rules of Menu Operation	24
Main Menu	24
Display Menu for Main Screen	25
Privacy Zone Mask Setup	26
Camera Module Setup	27
Motion Setup	31
Preset Setup	33
Swing Setup	36
Pattern Setup	37
Group Setup	38
System Initialization	40
⑤ Specifications	41
Dimension	42

 **Features****□ Camera Specifications**

- CCD Sensor : 1/4" Interline Transfer CCD
- Zoom Magnification : × 37 Optical Zoom, × 12 Digital Zoom (Max × 444 Zoom)
- Day & Night Function
- WDR (Wide Dynamic Range) Function
- HLC (High Light Compensation) Function
- EIS (Electronic Image Stabilization) Function
- Various Focus Mode : Auto-Focus / Manual Focus / Semi-Auto Focus.
- Independent & Simultaneous Camera Characteristic Setup in Preset operation

□ Powerful Pan/Tilt Functions

- Max. 360°/sec high speed Pan/Tilt Motion
- Using Vector Drive Technology, Pan/Tilt motions are accomplished in a shortest path. As a result, time to target view is reduced dramatically and the video on the monitor is very natural to watch.
- For jog operation using a controller, since ultra slow speed 0.05°/sec can be reached, it is very easy to locate camera to desired target view. Additionally it is easy to move camera to a desired position with zoom-proportional pan/tilt movement.

□ Preset, Pattern, Swing, Group, Privacy Mask and More...

- MAX. 127 Presets are assignable and characteristics of each preset can be set up independently, such as White Balance, Auto Exposure, Label, Digital Outputs and so on.
- Max. 8 set of Swing action can be stored. This enables to move camera repetitively between two preset positions with designated speed.
- Max. 4 of Patterns can be recorded and played back. This enables to move camera to follow any trajectory operated by joystick as closely as possible.
- Max. 8 set of Group action can be stored. This enables to move camera repetitively with combination of Preset or Pattern or Swing. A Group is composed of max. 20 entities of Preset/Pattern/Swings.
- Privacy Masks are assignable, not to intrude on other's privacy. (4 or 8 Privacy Zones)

□ PTZ(Pan/Tilt/Zoom) Control

- With RS-485 communication, max. 255 of cameras can be controlled at the same time.
- Pelco-D or Pelco-P protocol can be selected as a control protocol in the current version of firmware.

□ OSD(On Screen Display) Menu

- OSD menu is provided to display the status of camera and to configure the functions interactively.
- The information such as Camera ID, Pan/Tilt Angle, Alarm I/O and Preset can be displayed on screen.

□ Alarm I/O Functions

- 4 alarm sensor Inputs and 2 alarm Output relays are available.
- To reject external electric noise and shock perfectly, alarm sensor Input is decoupled with photo coupler and the relay is used for alarm output.
- The signal range of sensor input is from DC 5.0 to 12.0 volts to adopt various applications. Meanwhile, the maximum load of relay contact is AC 250V, 3A or DC 28V, 3A.
- A camera can be set to move to a Preset position or to run functions such as Pattern, Swing and Group when there are external sensor activations. Also “Post Alarm” function can be set, which is supposed to activate after pre-defined time period and sequentially in succession to the action by external sensor activation.
- Meanwhile, the output relay can be matched to some specific Preset positions to do counteractions such as turning on the light or sound the alarm.

□ Reserved Presets for Special Purpose

- Most camera characteristics can be set up easily and directly with reserved preset, not entering into OSD menu. For more information, refer to “Reserved Preset” in this manual.

□ Easy Installation and Perfect Outdoor Environment Compatibility

- Fans and heaters are built-in in camera for cold and hot temperature environment. Also idealistic mechanical design protects camera from water and dust.
- It is easy to install and maintain camera with terminal for cable connection in brackets.

Product & Accessories

□ Product & Accessories

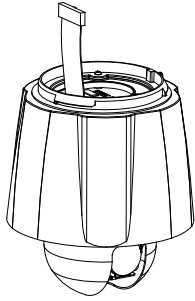

● Main Body *

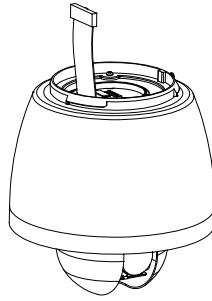

● Main Body (Sun-Shield) *

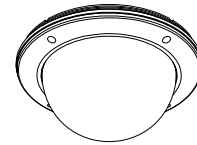

● Dome Cover

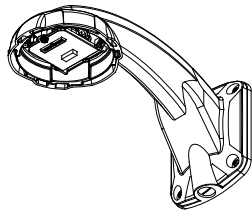

● Wall mount bracket **

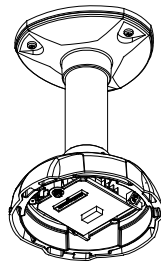

● Ceiling Mount Bracket **



● Screws

cf) *, ** should be option and different by purchase order.

□ Options

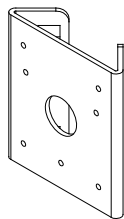

● Pole Mount Adapter

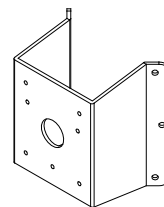

● Corner Mount Adapter

Parts Name & Functions

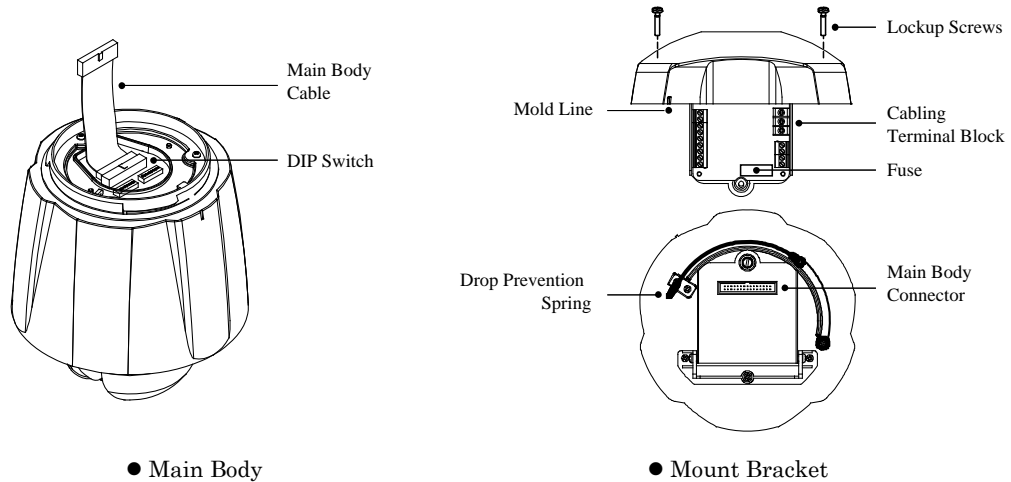

- **Main Body**
 - **Mount Bracket**
-
- **Dome Cover** Do not detach protection vinyl from dome cover before finishing all installation process to protect dome cover from scratches or dust.
 - **DIP Switch** Sets up camera ID and protocol.
 - **Main Body Cable**
Main Body Connector Enables signals and power to come and go between main body and mount bracket.
 - **Drop Prevention Spring** This part keeps the camera from dropping during installation and maintenance. After install the Bracket, please, hang the spring to the drop prevention hook of main body as shown in picture for further tasks.
 - **Lockup Screw** After assembling main body to bracket, screw main body to bracket to protect them from separation by vibration and so on.
 - **Fuse** If the fuse is burnt to protect your came from over-current damage, the fuse have to be replace with new one. The fuse specification is 250V 3A. However, we recommend consulting with supplier to remove the cause of over-current.
 - **Cabling Terminal Block** During installation, Power, Video, Communication, Alarm I/O cables are connected on to this cabling terminal block.
 - **Mold Line** Mark to assemble main body to bracket.

DIP Switch Setup

Before you install the camera, you should set the DIP switches to configure the camera ID, communication protocol.

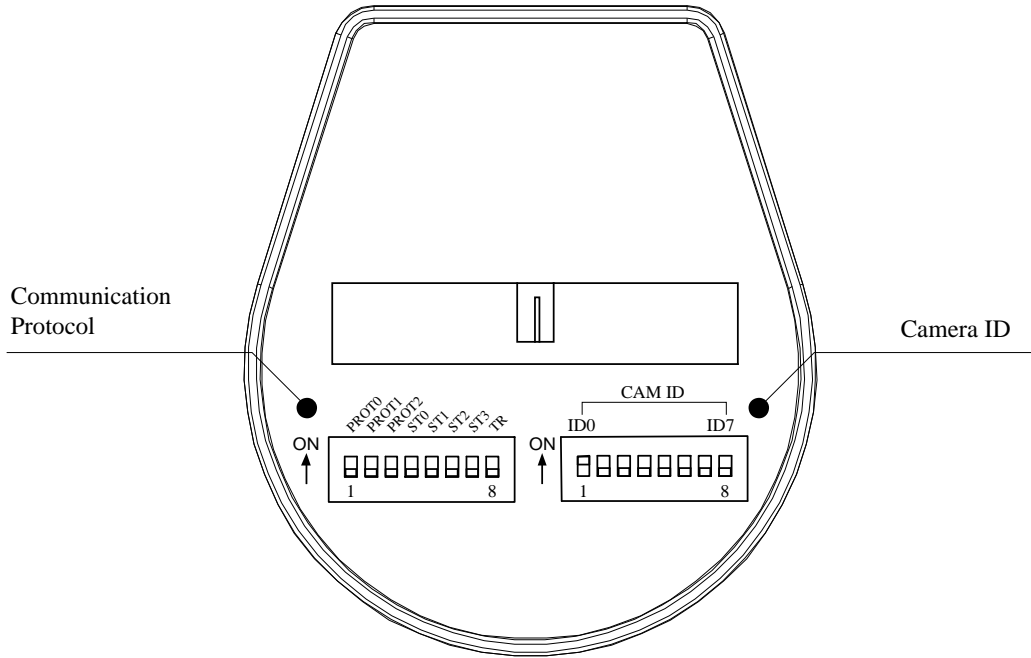

□ Camera ID Setup

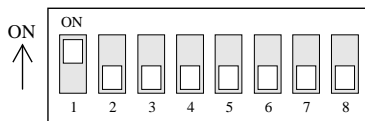

- ID number of camera is set using binary number. The example is shown bellow.

Pin	1	2	3	4	5	6	7	8
ID Value	1	2	4	8	16	32	64	128
ex) ID=5	on	off	on	off	off	off	off	off
ex) ID=10	off	on	off	on	off	off	off	off

- The range of ID is 1~255. **Do not use 0 as camera ID.** Factory default of Camera ID is 1.
- If you want to control a certain camera, you must match the camera ID with Cam ID setting of DVR or Controller.

□ Communication Protocol Setup

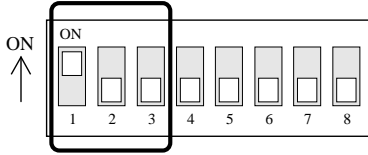

- Select the appropriate Protocol with DIP switch combination.

Switch State			Protocol/Baud rate
P0 (Pin 1)	P1 (Pin 2)	P2 (Pin 3)	
OFF	OFF	OFF	PELCO-D, 2400 bps
ON	OFF	OFF	PELCO-D, 9600 bps
OFF	ON	OFF	PELCO-P, 4800 bps
ON	ON	OFF	PELCO-P, 9600 bps
Otherwise			Reserved

- If you want to control using DVR or P/T controller, their protocol must be identical to camera. Otherwise, you can not control the camera.
- If you changed camera protocol by changing DIP S/W, the change will be effective after you reboot the camera.
- Factory default of protocol is “Pelco-D, 2400 bps”.

□ Sensor Type Setup

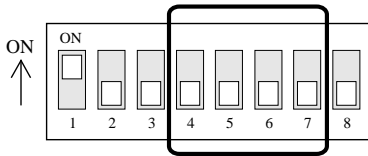

- If you want to use Alarm Input, the types of sensor must be selected. The sensor types are Normal Open and Normal.
- Normal Open Output Voltage is high state when sensor is activated.
- Normal Close Output Voltage is high state when sensor is not activated.

Pin No	Switch State	Sensor Type
ST0 (Pin 4)	ON	Sensor 1 : Normal Close Type
	OFF	Sensor 1 : Normal Open Type
ST1 (Pin 5)	ON	Sensor 2 : Normal Close Type
	OFF	Sensor 2 : Normal Open Type
ST2 (Pin 6)	ON	Sensor 3 : Normal Close Type
	OFF	Sensor 3 : Normal Open Type
ST3 (Pin 7)	ON	Sensor 4 : Normal Close Type
	OFF	Sensor 4 : Normal Open Type

- If sensor type is not selected properly, the alarm can be activated reversely.

□ Terminal resistor Setup

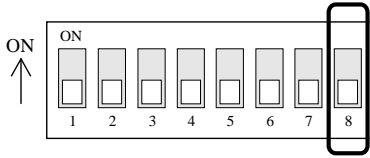

Terminal resistor is used if your system is one of following two cases.

Case1: Control cable between camera and controller is relatively very long (1:1 connection)

If communication cable is very long, the electrical signal will bound in the terminal point. This reflected signal cause distortion of original signal. Accordingly, the camera can be out of control. In this case, the terminal resistor of both sides i.e. camera and controller must be set to 'ON' state.

Case2: Multiple cameras are controlled at the same time

Due to similar reasons with case 1, the terminal resistors of controller and the last camera must be set to 'ON' state. Last camera means decided by cable length. Do not turn on the terminal resistor of all cameras.

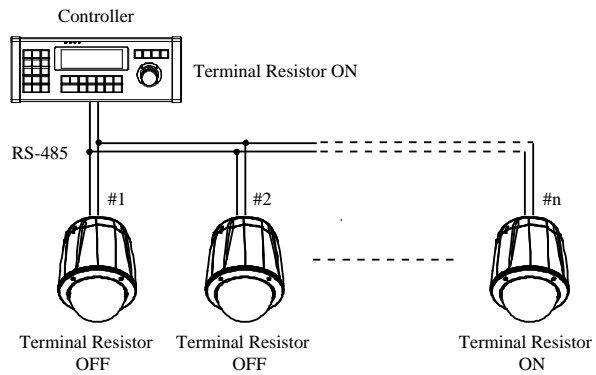

Installation using Wall Mount Bracket

- ① Install Wall Mount Bracket on wall.

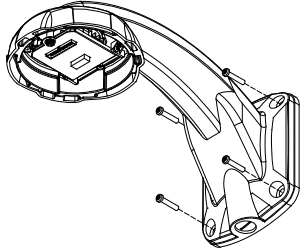

- ② Wire cables to terminal blocks on the PCB in Wall Mount Bracket.

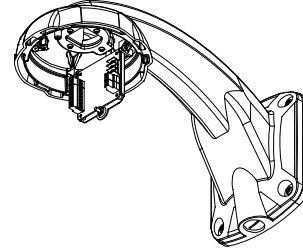

- ③ Hook up “Drop Prevention Spring” on main body to prevent camera from unexpected drop and connect Main Body Cable to Main Body Connector in Wall Mount Bracket.

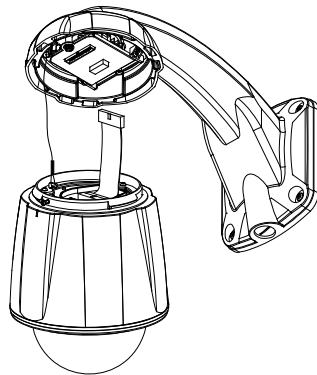

- ④ Line up the mold lines and assemble main body to Wall Mount Bracket.

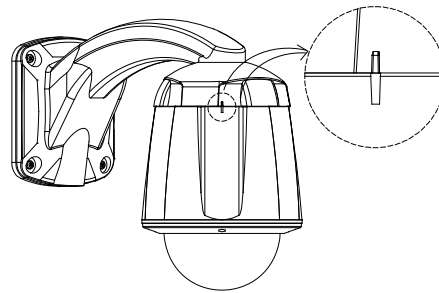

- ⑤ Turn main body on its axis in CW(Clockwise) direction and, after assembling them, screw main body to Wall Mount Bracket to protect them from separation by vibration or others.

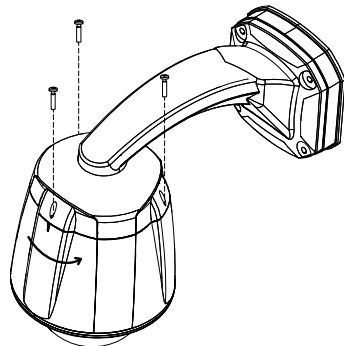

- ⑥ In case of using pipe, use the hole located on lower side of Wall Mount Bracket to fix pipe.

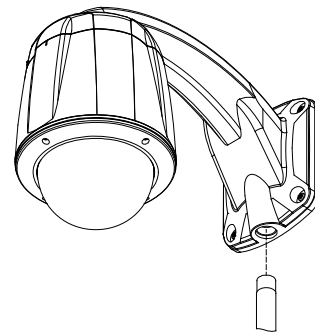

Installation using Ceiling Mount Bracket

- ① To pass cables to upside of ceiling, please make a hole with 50~60mm diameter on the ceiling panel and attach the Ceiling mount bracket on it.
- ② Wire cables to terminal blocks on the PCB in Ceiling Mount Bracket.

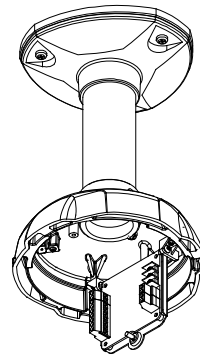
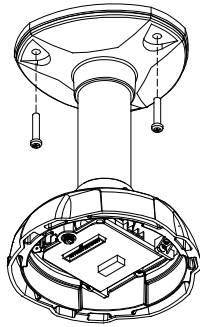

- ③ Hook up “Drop Prevention Spring” on main body to prevent camera from unexpected drop and connect Main Body Cable to Main Body Connector in Ceiling Mount Bracket.
- ④ Line up the mold lines and assemble main body to Ceiling Mount Bracket.

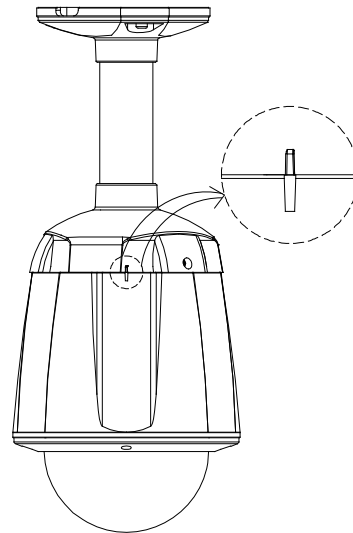
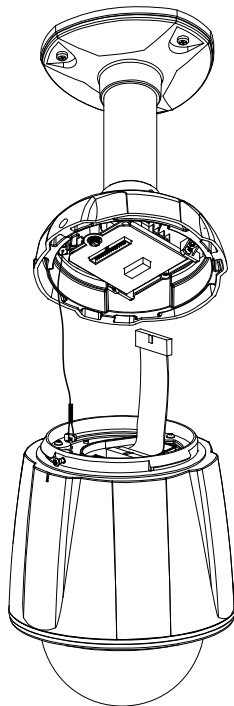

- ⑤ Turn main body on its axis in CW(Clockwise) direction and, after assembling them, screw main body to Ceiling Mount Bracket to protect them from separation by vibration or others.

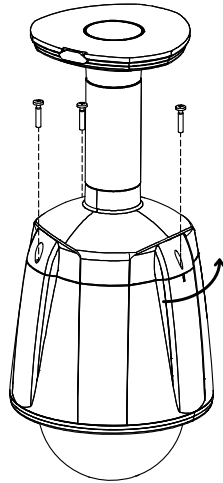

Gasket Installation

Install the included gasket by the following procedure to prevent your camera from dust, insects and so on through the hole for line connection.

- ① Pull out the protrusion of the Gasket and make a hole as large as lines can be through. Pass the cables through the hole and tie the hole and the cables with a tie cable. Make sure that the hole is perfectly sealed.
- ② Pull in the protrusion of the Gasket to the bracket.

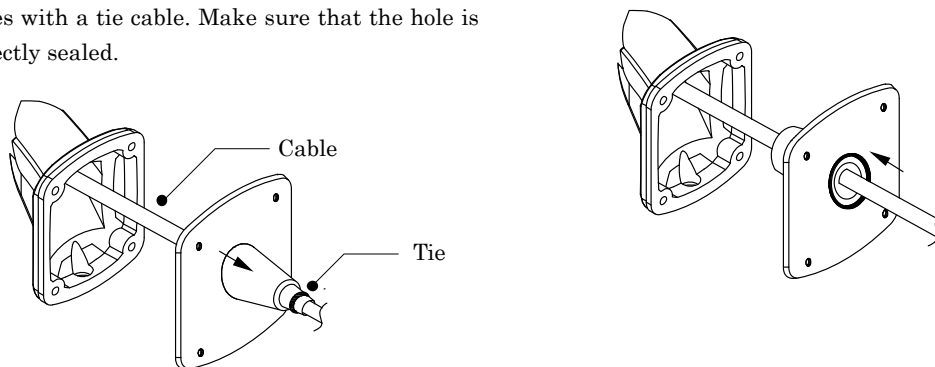

Cabling

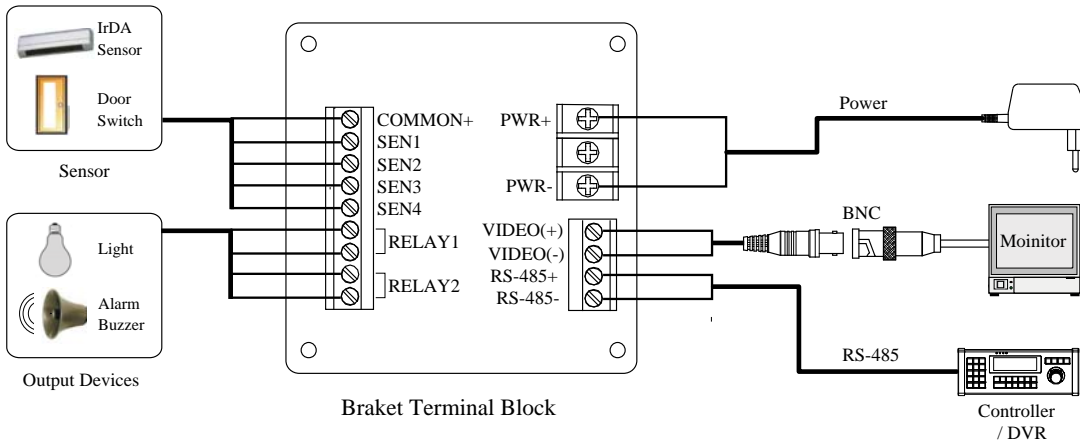

❑ Power Connection

- Please, check the voltage and current capacity of rated power carefully. Rated power is indicated in the back of main unit.

Rated Power	Input Voltage Range	Current Consumption
AC 24V	AC 17V ~ 29V	1.5 A

❑ Video Connection

- Connect with BNC coaxial cable.

❑ RS-485 Communication

- For PTZ control, connect this line to keyboard and DVR. To control multiple cameras at the same time, RS-485 communication lines of them is connected in parallel as shown below.

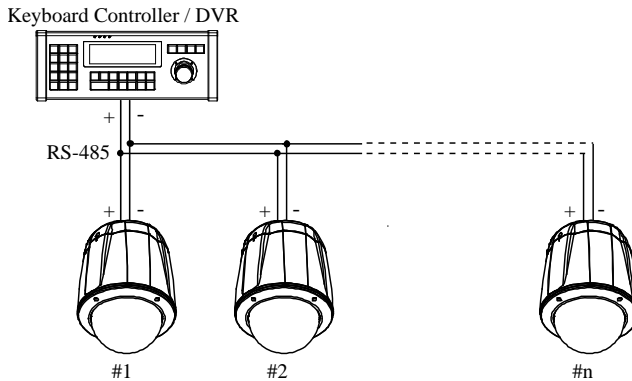

□ Alarm I/O Connection

● Sensor Input

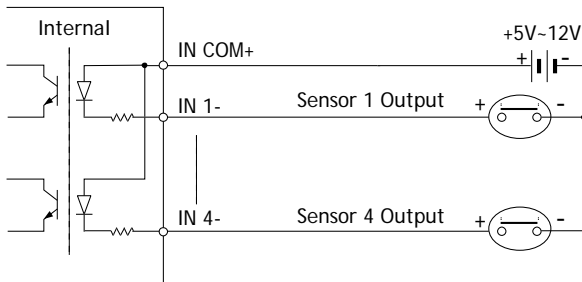

Before connecting sensors, check driving voltage and output signal type of the sensor. Since output signal types of the sensors are divided into Open Collector and Voltage Output type in general, the cabling must be done properly after considering these typed. Also, the sensor type, i.e. “Normal Open” or “Normal Close” in Dip switch in main body of camera must be set properly.

Signal	Description
IN COM+	Connect (+) cable of electric power source for Sensors to this port as shown in the circuit above.
IN1-, IN2-, IN3-, In4-	Connect output of sensors for each port as shown in the circuit above.

● Relay Output

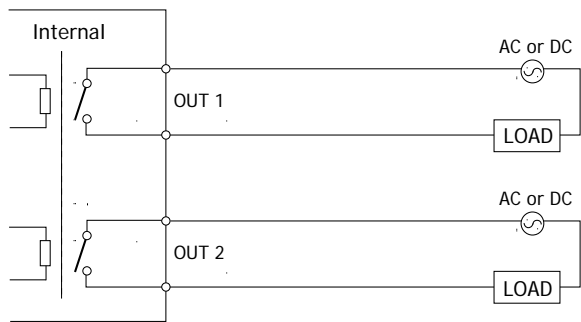

Maximum allowable electrical load of relay is shown bellow table.

Drive Power	DC Power	AC 110V Power	AC220V Power
Max. Load	DC 28V, 3A	AC110V, 3A	AC250V, 3A

Check points before operation

- Before power is applied, please check the cables carefully.
- The camera ID of the controller must be identical to that of the target camera. The camera ID can be checked by reading DIP switch of the camera.
- If your controller supports multi-protocols, the protocol must be changed to match to that of the camera.
- If you changed camera protocol by changing DIP switch, the change will be effective after you reboot the camera.
- Since the operation method can be different for each controller available, refer to the manual for your controller if camera can not be controlled properly. The operation of this manual is based on the standard Pelco® Controller.

Preset and Pattern Function Pre-Check

- Check how to operate preset and pattern function with controller or DVR in advance to operate camera function fully when using controller or DVR.
- Refer to the following table when using standard Pelco® protocol controller.

< Go Preset >	Input [Preset Number] and press [Preset] button shortly.
< Set Preset >	Input [Preset Number] and press [Preset] button for more than 2 seconds.
< Run Pattern >	Input [Pattern Number] and press [Pattern] button shortly.
< Set Pattern >	Input [Pattern Number] and press [Pattern] button for more than 2 seconds.

- If controller or DVR has no pattern button or function, use shortcut keys with preset numbers. For more information, refer to “Reserved Preset” in this manual.

Starting OSD Menu

- Function Using the OSD menu, Preset, Pattern, Swing, Group and Alarm I/O function can be configured for each application.
- Enter Menu <Go Preset> [95]

Reserved Preset

- Description Some Preset numbers are reserved to special functions.
- Function <Go Preset> [95] : Enters into OSD menu
- <Go Preset> [131~134] : Runs Pattern Function 1 ~ 4
- <Go Preset> [141~148] : Runs Swing Function 1 ~
- <Go Preset> [151~158] : Runs Group Function 1 ~ 8
- <Go Preset> [161~162] : Sets Relay Output 1 ~ 2 to OFF
- <SetPreset> [161~162] : Sets Relay Output 1 ~ 2 to ON
- <Go Preset> [167] : Set Zoom Proportional Function to ON
- <Set Preset> [167] : Set Zoom Proportional Function to OFF
- <Go Preset> [170] : Sets Camera BLC or WDR Mode to OFF
- <Go Preset> [171] : Sets Camera BLC or WDR Mode to ON
- <Go Preset> [174] : Sets Camera Focus Mode to AUTO
- <Go Preset> [175] : Sets Camera Focus Mode to Manual
- <Go Preset> [176] : Sets Camera Focus Mode to SEMI-AUTO
- <Go Preset> [177] : Sets Day & Night Mode to AUTO
- <Go Preset> [178] : Sets Day & Night Mode to NIGHT
- <Go Preset> [179] : Sets Day & Night Mode to DAY
- <Go Preset> [180] : Sets Line-Lock Mode to OFF
- <Go Preset> [181] : Sets Line-Lock Mode to ON
- <Go Preset> [190] : Sets OSD Display Mode to AUTO (Except Privacy Mask)
- <Go Preset> [191] : Sets OSD Display Mode to OFF (Except Privacy Mask)
- <Go Preset> [192] : Setting OSD Display Mode to ON (Except Privacy Mask)
- <Go Preset> [193] : Sets all Privacy Mask Display to OFF
- <Go Preset> [194] : Sets all Privacy Mask Display to ON

Preset

- **Function** Max. 127 positions can be stored as Preset position. The Preset number can be assigned from 1 to 128, but 95 is reserved for starting OSD menu.
Camera characteristics (i.e. White Balance, Auto Exposure) can be set up independently for each preset. Label should be blank and Relay Outputs should be set to OFF as default. All characteristics can be set up in OSD menu.
- **Set Preset** <Set Preset> [1~128]
- **Run Preset** <Go Preset> [1~128]
- **Delete Preset** To delete Preset, use OSD menu.

Swing

- **Function** By using Swing function, you can make camera to move between 2 Preset positions repeatedly. When swing function runs, camera moves from the preset assigned as the 1st point to the preset assigned as the 2nd point in CW(Clockwise) direction. Then camera moves from the preset assigned as the 2nd point to the preset assigned as the 1st point in CCW(Counterclockwise) direction.

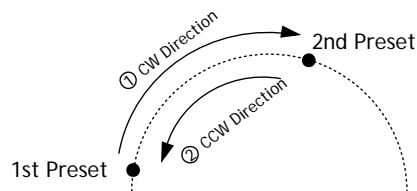

In case that the preset assigned as the 1st point is same as the preset assigned as the 2nd point, camera turns on its axis by 360° in CW(Clockwise) direction and then it turns on its axis by 360° in CCW(Counterclockwise) direction.

Speed can be set up from 1°/sec to 180°/sec.

- **Set Swing** To set Swing, use OSD menu.
- **Run Swing** Method 1) <Run Pattern> [Swing NO.+10] ex) Run Swing 3 : <Run Pattern> [13]
Method 2) <Go Preset> [Swing NO.+140] ex) Run Swing 3 : <Go Preset> [143]
- **Delete Swing** To delete Swing, use OSD menu.

Pattern

- **Function** Pattern Function is that a camera memorizes the path (mostly curve path) by joystick of controller for assigned time and revives the path exactly as it memorized.
4 Patterns are available and Maximum 1200 communication commands can be stored in a pattern.

- **Set Pattern** Pattern can be created by one of following two methods.

Method 1) <Set Pattern> [Pattern NO.]

- Pattern editing screen is displayed as bellow.

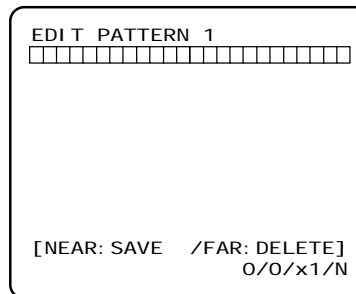

- Movement by Joystick and preset movement can be memorized in a pattern.
- The rest memory size is displayed in progress bar.
- To save the recording, press **NEAR** key and to cancel, press **FAR** key.

Method 2) OSD Using OSD Menu: See the section “How to use OSD Menu”.

- **Run Pattern** Method 1) <Run Pattern> [Pattern NO.] ex) Run Pattern 2 : <Run Pattern> [2]
Method 2) <Go Preset> [Pattern NO.+130] ex) Run Pattern 2: <Go Preset> [132]
- **Delete Pattern** Use OSD menu to delete a Pattern.

Group

- **Function** The group function allows running sequence of Presets, Pattern and/or Swings. Max 8 group can be stored. Each group can have max 20 action entities which can be preset, pattern or swing. Preset speed can be set up and the repeat number of Pattern & Swing can be set up in Group setup. Dwell time between actions can be set up also.

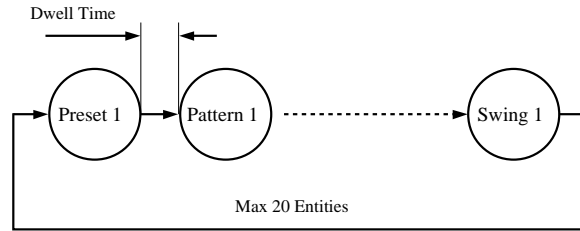

- **Set Group** Use OSD Menu to create a Group.
- **Run Group** Method 1) <Run Pattern> [Group NO.+20] ex) Run Group 7 : <Run Pattern> [27]
Method 2) <Go Preset> [Group NO.++150] ex) Run Group 7 : <Go Preset> [157]
- **Delete Group** Use OSD Menu to delete.

Other Functions

- **Power Up Action** This function enables to resume the last action executed before power down. Most of actions such as Preset, Pattern, Swing and Group are available for this function but Jog actions are not available to resume.
- **Auto Flip** In case that tilt angle arrives at the top of tilt orbit(90°), zoom module camera turns on its axis by 180° at the top of tilt orbit and moves to opposite tilt direction (180°) to keep tracing targets. If this function is set to OFF, tilt movement range is 0 ~ 95°.
- **Parking Action** This function makes a camera automatically run a pre-defined action if there is no command from controller for a pre-defined time period. "Wait Time" means how long a camera should wait for from the previous-last (most recent) command before running the pre-defined action. It can be set to 1 second ~ 3 hours.
- **Alarm I/O** 4 Alarm Input and 2 Alarm output (Relay output) are used. When external sensors activate, a camera runs pre-defined actions such as Preset, Pattern, Swing and Group. Also, the output relay can be matched to some specific preset positions to do counteractions such as turning on the light or sounding the alarm. It is noted that the latest alarm input is effective if multiple sensors are activated.
- **Privacy Zone Mask** To protect privacy, MAX. 4 or 8 Privacy Masks can be created on the arbitrary position to hide objects such as windows, shops or private house. With Spherical Coordinates system, powerful Privacy Zone Mask function is possible.
- **GLOBAL/LOCAL Image Setup** WB(White Balance) and AE(Auto Exposure) can be set up independently for each preset. There are 2 modes, "Global" mode & "Local" mode. The Global mode means that WB or AE can be set up totally and simultaneously for all presets in "ZOOM CAMERA SETUP" menu. The Local mode means that WB or AE can be set up independently or separately for each preset in each preset setup menu. Each Local WB/AE value should activate correspondingly when camera arrives at each preset location.

During jog operation, Global WB/AE value should be applied. All Local WB/AE value do not change although Global WB/AE value changes.
- **SemiAuto Focus** This mode exchanges focus mode automatically between Manual Focus mode and Auto Focus mode by operation. Manual Focus mode activates in preset operation and Auto Focus mode activates during jog operation. With Manual mode at presets, Focus data is memorized in each preset in advance and camera calls focus data in correspondence with presets as soon as camera arrives at a preset. It should shorten time to get focuses.

Focus mode changes to Auto Focus mode automatically when jog operation starts.

OSD Display of Main Screen

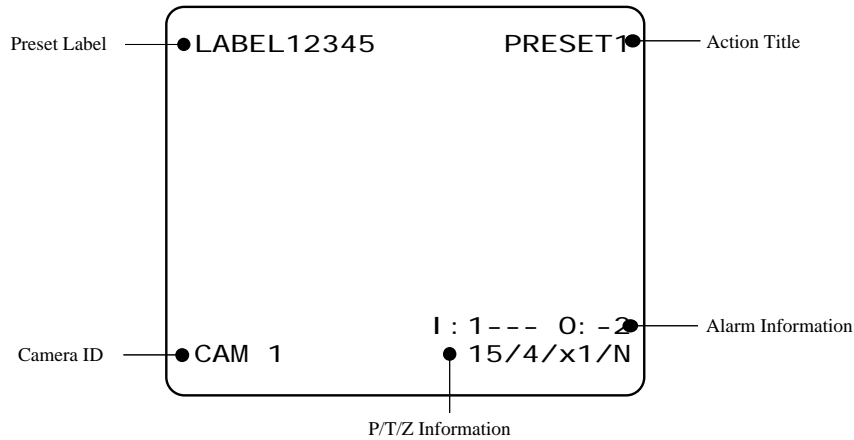

- **P/T/Z Information** Current Pan/Tilt angle in degree, zoom magnification and a compass direction.
- **Camera ID** Current Camera ID(Address).
- **Action Title** Followings are possible Action Titles and their meaning.

"SET PRESET xxx"	When Preset xxx is stored
"PRESET xxx"	When camera reach to Preset xxx
"PATTERN x"	When Pattern x is in action
"SWGx/PRESET xxx"	When Swing x is in action
"UNDEFINED"	When undefined function is called to run
- **Preset Label** The Label stored for specific Preset.
- **Alarm Information** This information shows current state of Alarm I/O. The character 'O' of first line stands for Output and 'I' of second line means Input. If an I/O point is **ON** state it will show a number corresponding to each point. If an I/O point is **OFF** state, '-' will be displayed.
Ex) Point 2 & 3 of inputs are **ON** and Point 1 of outputs is **ON**, OSD will show as below

I : -23- O: 1-

General Rules of Key Operation for Menu

- The menu items surrounded with () always has its sub menu.
- For all menu level, to go into sub menu, press **NEAR** key.
- To go to up-one-level menu, press **FAR** key.
- To move from items to item in the menu, use joystick in the **Up/Down** or **Left/Right**.
- To change a value of an item, use **Up/Down** of the joystick in the controller.
- Press **NEAR** key to save values and Press **FAR** key to cancel values.
- Specifications and functions should be different by models.

Main Menu

```
SPEED DOME CAMERA
-----
-><SYSTEM I NFORMATION>
<DI SPLAY SETUP>
<DOME CAMERA SETUP>

<SYSTEM I NI TI ALI ZE>

EXI T
```

- System Information Displays system information and configuration.
- Display Setup Enable/Disable of OSD display on Main Screen.
- Dome Camera Setup Configure various functions of this camera.
- System Initialize Initializes system configuration and sets all data to factory default configuration.

Display Setup

```

DI SPLAY SETUP
-----
->CAMERA ID          ON
PTZ INFORMATION     AUTO
ACTION TITLE       AUTO
PRESET LABEL       AUTO
ALARM I/O          AUTO
<SET NORTH DIRECTI ON>
<PRIVACY ZONE>

BACK
EXIT
  
```

This menu defines Enable/Disable of OSD display on Main Screen. If an item is set to be AUTO, the item is displayed only when the value of it is changed.

- Camera ID [ON/OFF]
- PTZ Information [ON/OFF/AUTO]
- Action Title [ON/OFF/AUTO]
- Preset Label [ON/OFF/AUTO]
- Alarm I/O [ON/OFF/AUTO]

□ Compass Direction Setup

```

SET NORTH DIRECTI ON
-----

MOVE TO TARGET POSITION
[NEAR: SAVE /FAR: CANCEL
  
```

Set North to assign compass direction as criteria. Move camera and press **NEAR** button to save.

PRIVACY ZONE MASK Setup

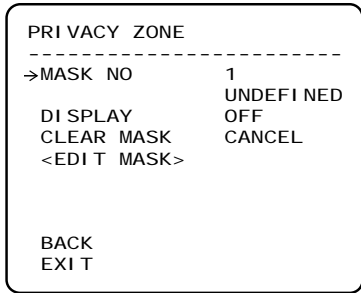

Select area in image to mask.

- Mask No [1~4] or [1~8]
Select Mask number. If the selected mask has already data, camera moves as it was set. Otherwise, "UNDEFINED" will be displayed under "Mask NO".
- Display [ON/OFF]
Sets if camera makes mask shows or not on images.
- Clear Mask [CANCEL/OK]
Deletes data in the selected mask NO.

□ Privacy Zone Area Setup

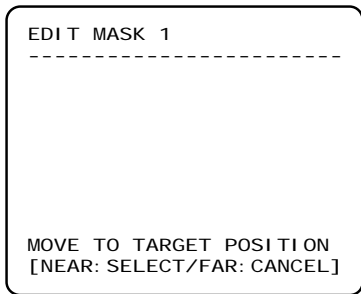

Move camera to area to mask. Then the menu to adjust mask size will be displayed.

□ Privacy Zone Size Adjustment

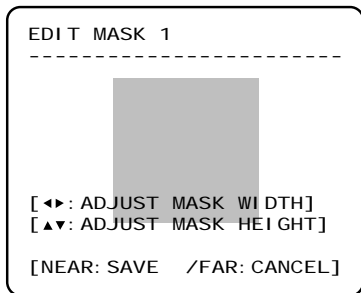

Adjust mask size. Use joystick or arrow buttons to adjust mask size.

- ◀ ▶ (Left/Right) Adjusts mask width.
- ▲ ▼ (Up/Down) Adjusts mask height.

CAMERA SETUP

ZOOM CAMERA SETUP	

-> FOCUS MODE	SEMI AUTO
DIGITAL ZOOM	ON
LINE LOCK	OFF
IMAGE FLIP	OFF
SHARPNESS	16
STABILIZATION	OFF
<WHITE BALANCE SETUP>	
<AUTO EXPOSURE SETUP>	
BACK	
EXIT	

Setup the general functions of zoom camera module.

- Focus Mode [AUTO/MANUAL/SEMIAUTO]
Sets camera focus mode.
○ SEMIAUTO Mode
This mode exchanges focus mode automatically between Manual Focus mode and Auto Focus mode. Manual Focus mode activates in preset operation and Auto Focus mode activates when jog operation starts.
With Manual mode at presets, Focus data is memorized in each preset in advance and camera calls focus data in correspondence with presets as soon as camera arrives at a preset.
- Digital Zoom [ON/OFF]
Sets digital zoom function to ON/OFF. If this is set to OFF, optical zoom function runs but zoom function stops at the end of optical zoom magnification.
- Line Lock [ON/OFF]
If Line lock sync is ON, video signal is synchronized with AC power.
- Image Flip [ON/OFF]
Flip the Image. When the camera is installed as Desktop type, set to ON to get proper images.
- Sharpness [0~31] or [0~100] or [0~32]
Sets image sharpness.
- Stabilization [ON/OFF]
Compensates image vibration by wind or others. The image resolution with this function should be lower than normal image resolution when this function is turned on because it use the digital zoom function. Also this function may not work properly in the following conditions.
 - Dark scene or Low contrast scene
 - High frequency vibration
 - During Pan/Tilt/Zoom/Focus moving
 - During Iris/Shutter/Gain moving

□ White Balance Setup

```

WB SETUP - GLOBAL
-----
->WB MODE          AUTO
●RED ADJUST       ---
●BLUE ADJUST      ---

BACK
EXIT
    
```

- WB Mode [AUTO/MANUAL]
In Manual mode, Red and Blue level can be set up manually
- Red Adjust [10~60] or [0~255]
- Blue Adjust [10~60] or [0~255]

□ Auto Exposure Setup

```

AE SETUP - GLOBAL
-----
->BACKLIGHT       OFF
DAY/NIGHT         AUTO
BRIGHTNESS        50
IRIS              AUTO
SHUTTER           ESC
AGC               MIDDLE
SSNR              MIDDLE
SENS-UP           <AUTO>
BACK
EXIT
    
```

- Backlight [OFF/LOW/MIDDLE/HIGH] or [OFF/WDR/HLC]
Sets Backlight Compensation. If a bright backlight is present, the subjects in the picture may appear dark or as a silhouette. Backlight compensation enhances objects in the center of the picture. The camera uses the center of picture to adjust the iris. If there is a bright light source outside of this area, it will wash out to white. The camera will adjust the iris so that the object in the sensitive area is properly exposed.
The some models have WDR(Wide Dynamic Range) function and HLC(High Light Compensation) function, which are better function that BLC.
- Day/Night [AUTO/DAY/NIGHT]
- Brightness [0~100]
Adjusts brightness of images. Iris, Shutter Speed and Gain are adjusted automatically in correspondence with this value.
- IRIS [AUTO/MANUAL(0~100)] or [AUTO/MANUAL(F1.6~F28)]
If Iris is set to Auto, Iris should have highest priority in adjusting AE and Shutter Speed should be fixed.
If Iris is set to Manual, Iris should be fixed and Iris has lower priority in adjusting AE, in comparison with others.

- Shutter Speed [ESC/A.Flicker/Manual(×128~1/120000 sec)] or [ESC/A.Flicker/Manual((256~1/120000 sec)]
 If Iris is set to Manual and Shutter Speed is set to ESC, Shutter Speed should have highest priority. If Shutter Speed is set to A.Flicker, to remove Flicker, Shutter Speed should be set to 1/100 sec. for NTSC and 1/120 for PAL.
- (AGC [OFF/LOW/MIDDLE/HIGH] or [OFF/LOW/MIDDLE/HIGH/MANUAL(5~41 dB)]
 Enhances image brightness automatically in case that luminance level of image signal is too low.
- (SSNR [OFF/LOW/MIDDLE/HIGH]
 Enhances images by deducting noises when gain level of images is too high.
- (SENS-UP [AUTO(2~128)/OFF] or [AUTO(2~256)/OFF]
 Activates Slow Shutter function when luminance of image (signal) is too dark.

□ WDR (Wide Dynamic Range) Setup

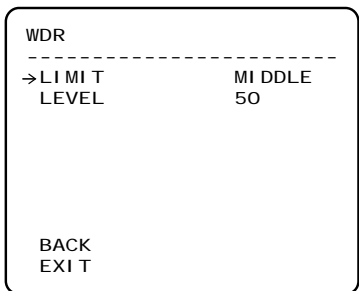

- Limit [LOW/MIDDLE/HIGH]
- Level [0~100]

□ HLC (High Light Compensation) Setup

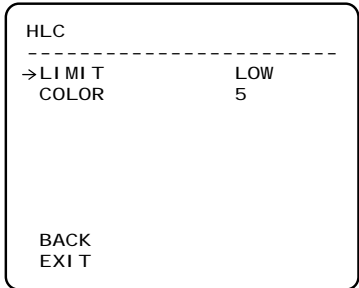

● Limit

[AUTO/MANUAL]

When there are too bright lights, this function blocks light sources on the images to have better images. For example, when there is a car coming to a camera at night, this function blocks car headlights to recognize its number plate.

● Level

[0~10]

Assigns colors of masks to block light sources

Motion Setup

```

MOTION SETUP
-----
->MOTION LOCK      OFF
PWR UP ACTION     ON
AUTO FLIP         ON
JOG MAX SPEED     120/SEC
JOG DIRECTION     INVERSE
FRZ IN PRESET     OFF
<PARKING ACTION SETUP>
<ALARM INPUT SETUP>
BACK
EXIT

```

Setup the general functions of Pan/Tilt motions.

- Motion Lock [ON/OFF]
If Motion Lock is set to ON, it is impossible to set up and delete Preset, Swing, Pattern and Group. It is possible only to run those functions. To set up and delete those functions, enter into OSD menu.
- Power Up Action [ON/OFF]
Refer to "Other Functions" section.
- Auto Flip [ON/OFF]
Refer to "Other Functions" section.
- Jog Max Speed [1°/sec ~360°/sec]
Sets maximum jog speed. Jog speed is inversely proportional to zoom magnification. As zoom magnification goes up, pan/tilt speed goes down.
- Jog Direction [INVERSE/NORMAL]
If you set this to 'Inverse', the view in the screen is moving same direction with jog tilting. If 'Normal' is selected, the view in the screen is moving reversely.
- Freeze in Preset [ON/OFF]
At start point of preset movement, camera starts freezing the image of start point. Camera keeps displaying the image of start point during preset movement and does not display the images which camera gets during preset movement. As soon as camera stops at preset end point, camera starts displaying live images which it gets at preset end point.

□ Parking Action Setup

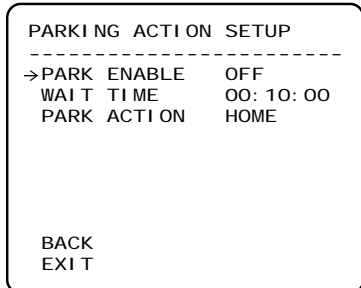

If Park Enable is set to ON, camera runs assigned function automatically if there is no PTZ command during assigned "Wait Time".

- Park Enable [ON/OFF]
- Wait Time [1~59 sec/1~180 minute]
A camera automatically run a "Part Action" if there is no command from controller for this time period.
- Park Action [HOME/PRESET/PATTERN/SWING/GROUP/PREV ACTION]
Sets what a camera should do when there is no command from a controller for the pre-defined time period ("WAIT TIME"). If Park Action is set to "HOME" , the camera moves to the home position which is memorized when the system boots. If Park Action is set to "PREV. ACTION" , the camera runs the previous action which it ran most recently.

□ Alarm Input Setup

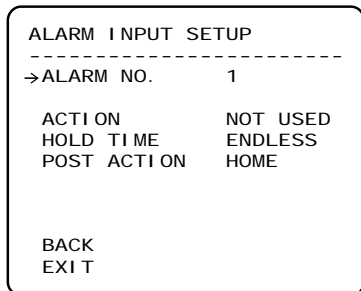

- Alarm No [1~4]
Selects a sensor number to set up.
- Action [NOT USED/PRESET/PATTERN/SWING/GROUP]
Sets actions to run when sensor is input.
- Hold Time [ENDLESS/1~59 sec/1~180 minute]
Sets the time period for the action which is run by external sensor activation. After the time period passes, the action pre-defined in "Post Action" runs sequentially in succession to the action by external sensor activation. If this option is set to "ENDLESS" , "Post Action" does not activate.
- Post Action [HOME/PRESET/PATTERN/SWING/GROUP/PREV ACTION]
Sets the action that a camera should run after the time period in "HOLD TIME" passes

PRESET Setup

```

PRESET SETUP
-----
->PRESET NO.    1

CLR PRESET     CANCEL
<EDIT SCENE>
<EDIT LABEL>  LABEL123
<RELAY OUT>   1-
CAM ADJUST     GLOBAL

BACK
EXIT
  
```

- Preset Number [1~128]
If a selected preset is already defined, camera moves to pre-defined position and preset characteristics such as Label and Relay Outputs show on monitor. If a selected preset is not defined, "UNDEFINED" shows on monitor.
- Clear Preset [CANCEL/OK]
Delete current Preset data
- Edit Preset Scene Redefine current Preset scene position (i.e. PTZ).
- Edit Preset Label Edits Label to show on monitor when preset runs. MAX. 10 alphabets are allowed.
- Edit Relay Out Define Relay output. If an Output point is **ON** state it will show a number corresponding to each point. Otherwise, '-' will be displayed.
- CAM Adjust [GLOBAL/LOCAL]
WB(White Balance) and AE(Auto Exposure) can be set up independently for each preset. There are 2 modes, "Global" mode & "Local" mode. The Global mode means that WB or AE can be set up totally and simultaneously for all presets in "ZOOM CAMERA SETUP" menu.
The Local mode means that WB or AE can be set up independently or separately for each preset in each preset setup menu. Each Local WB/AE value should activate correspondingly when camera arrives at each preset location. During jog operation, Global WB/AE value should be applied.
All Local WB/AE value should not change although Global WB/AE value changes. If "Local" is selected, Menu to set WB/AE shows on monitor.

❑ Edit Preset Scene

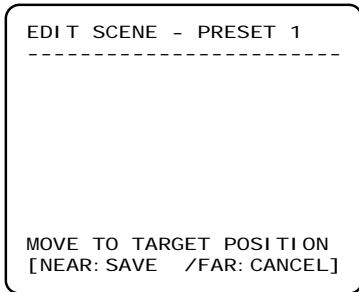

- ① Using Joystick, move camera to desired position.
- ② By pressing **NEAR** key, save current PTZ data.
- ③ Press **FAR** key to cancel.

❑ Edit Preset Label

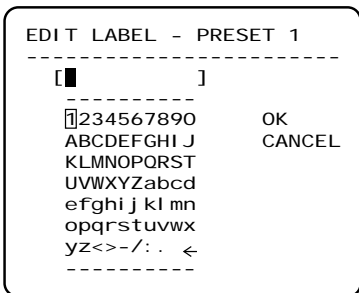

- ① Edits label to show on monitor when camera arrives at presets. In Edit Label menu, a reverse rectangular is cursor. As soon as finishing selecting alphabet, cursor moves to the next digit.

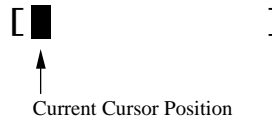

- ② Using **Left/Right/Up/Down** of joystick, move to an appropriate character from the Character set. To choose that character, press the **NEAR** key.

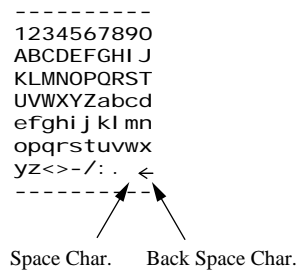

If you want to use blank, choose Space character (" "). If you want to delete a character before, use back space character ("←").

- ③ If you complete the Label editing, move cursor to "OK" and press **NEAR** key to save completed label. To abort current change, move cursor to "Cancel" and press **NEAR** key.

□ Relay Out Setup

```
RELAY OUT - PRESET 1
-----
->RELAY OUT 1    OFF
  RELAY OUT 2    OFF

BACK
EXIT
```

● Relay Out × [ON/OFF]

Sets Relay Outputs for assigned preset.

Swing Setup

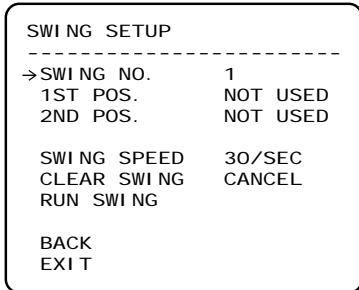

● **Swing Number** [1~8]
 Selects Swing number to edit. If a selected Swing has not defined, "NOT USED" is displayed in 1st Position and 2nd Position

● **1st Position** [PRESET 1~128]
2nd Position Set up the 2 position for Swing function. If a selected preset is not defined, "UNDEFINED" will be displayed as shown below.

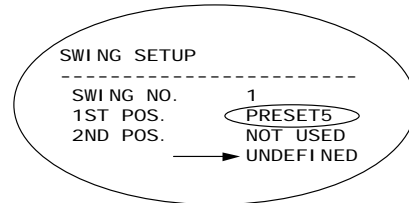

When swing function runs, camera moves from the preset assigned as the 1st point to the preset assigned as the 2nd point in CW(Clockwise) direction. Then camera moves from the preset assigned as the 2nd point to the preset assigned as the 1st point in CCW(Counterclockwise) direction. In case that the preset assigned as the 1st point is same as the preset assigned as the 2nd point, camera turns on its axis by 360° in CW direction and then it turns on its axis by 360° in CCW direction.

● **Swing Speed** [1°/sec ~180°/sec]
 Sets Swing speed from 1°/sec to 180°/sec.

● **Clear Swing** [CANCEL/OK]
 Deletes current Swing data.

● **Run Swing**
 Runs Swing for the test purposes to check if it works properly.

Pattern Setup

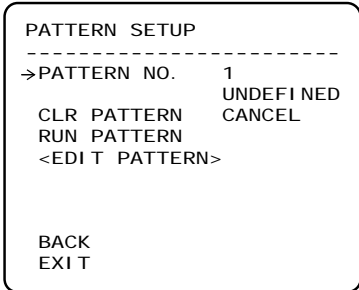

- Pattern Number [1~4]
Selects Pattern number to edit.
If a selected pattern number is not defined, "UNDEFINED" will be displayed under selected pattern number.
- Clear Pattern [CANCEL/OK]
Deletes data in current pattern
- Run Pattern
Runs Pattern for the test purposes to check if it works properly.
- Edit Pattern
Starts editing pattern.

□ Edit Pattern

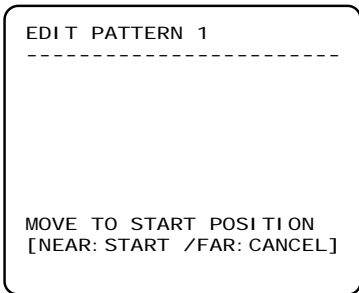

① By using Joystick, move to start position with appropriate zoom. To start pattern recording, press **NEAR** key. To exit this menu, press **FAR** key.

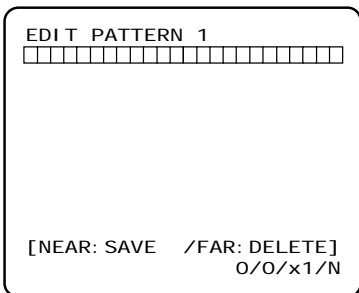

② Move camera with joystick of controller or run preset function to memorize the path (mostly curve path) in a selected pattern. The total memory size and the rest memory size is displayed in the form of bar. Maximum 1200 communication commands can be stored in a pattern.

③ To save data and exit, press **NEAR** key. To cancel recording and delete record data, press **FAR** key.

Group Setup

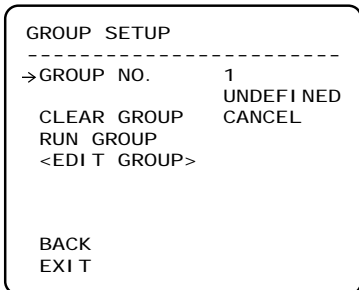

- **Group Number** [1~8]
Selects Group number to edit.
If a selected Group number is not defined, "UNDEFINED" will be displayed under selected Group number.
- **Clear Group** [CANCEL/OK]
Deletes data in current Group
- **Run Group** [CANCEL/OK]
Runs Group for the test purposes.
- **Edit Group** [CANCEL/OK]
Starts editing Group.

□ Edit Group

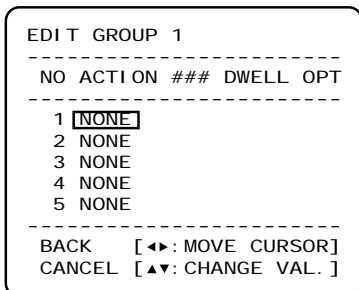
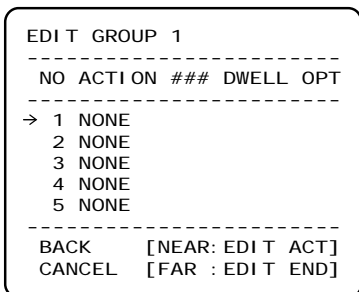
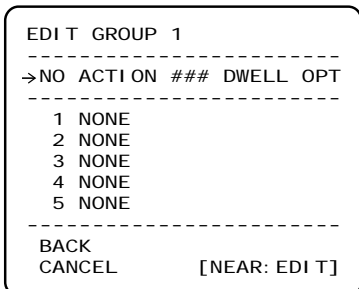

- ① Press **Near** key in "NO" list to start Group setup.
- ② Note that MAX. 20 Functions are allowed in a Group. Move cursor up/down and press **Near** key to set up.
- ③ Set up Action, Dwell time and Option. Note that selected item is displayed in reverse. Move cursor **Left/Right** to select items and move cursor **Up/Down** to change each value.
 - **Action ###** [NONE/PRESET/SWING/PATTERN]
 - **DWELL** [0 second ~ 4 minutes]
Sets Dwell Time between functions
 - **OPT** Option. It should be preset speed when preset is set in Action. It should be the number of repeat when Pattern or Swing is selected in Action

```

EDIT GROUP 1
-----
NO ACTION ### DWELL OPT
-----
1 NONE
2 NONE
3 NONE
4 NONE
5 NONE
-----
BACK  [◀▶: MOVE CURSOR]
CANCEL [▲▼: CHANGE VAL.]
    
```

- ④ Set up items such as Action, ###, Dwell and OPT.

```

EDIT GROUP 1
-----
NO ACTION ### DWELL OPT
-----
→ 1 PRESET  1 00:03 360
2 NONE
3 NONE
4 NONE
5 NONE
-----
BACK  [NEAR: EDIT ACT]
CANCEL [FAR : EDIT END]
    
```

- ⑤ After finishing setting up a Action, press **NEAR** key to one-upper-level menu(Step ②). Move cursor **Up/Down** to select Action number and repeat Step ② ~ Step ④ to edit selected Group.

```

EDIT GROUP 1
-----
NO ACTION ### DWELL OPT
-----
→ 1 PRESET  1 00:03 360
2 NONE
3 NONE
4 NONE
5 NONE
-----
BACK  [NEAR: EDIT ACT]
CANCEL [FAR : EDIT END]
    
```

- ⑥ After finishing setting up all Actions, press **FAR** key to exit. Then cursor should be moved to "BACK". Press **NEAR** key to save data.

System Initialization

```

SYSTEM I N I T I A L I Z E
-----
->CLEAR ALL DATA      NO
●CLR DISPLAY SET      NO
●CLR CAMERA SET       NO
●CLR MOTION SET       NO
●CLR EDIT DATA       NO
REBOOT CAMERA         NO
REBOOT SYSTEM         NO

BACK
EXIT
    
```

- Clear All Data Deletes all configuration data such as display, camera, motion setup and so on.
- Clear Display Set Initializes Display Configuration
- Clear Camera Set Initializes Camera Configuration
- Clear Motion Set Initializes Motion Configuration
- Clear Edit Data Deletes Preset Data, Swing Data, Pattern Data and Group Data
- Reboot Camera Reboots Zoom Camera module
- Reboot System Reboots Speed Dome Camera

□ Initial Configuration Table

● Display Configuration		● Camera Configuration	
Camera ID	ON	Focus Mode	SemiAuto
PTZ Information	AUTO	Digital Zoom	ON
Action Title	AUTO	Line Lock	OFF
Preset Label	AUTO	Sharpness	16
Alarm I/O	AUTO	Stabilization	OFF
North Direction	Pan 0°	Image Flip	OFF
Privacy Zone	Undefined	White Balance	AUTO
		Backlight	OFF
		Day&Night	AUTO
		Brightness	50
		Iris	AUTO
		Shutter	ESC
		AGC	MIDDLE
		SSNR	MIDDLE
		SENS-UP	AUTO
● Motion Configuration		● User Defined Data	
Motion Lock	OFF	Preset 1~128	Undefined
Power Up Action	ON	Swing 1~8	Undefined
Auto Flip	ON	Pattern 1~4	Undefined
Jog Max Speed	120°/sec	Group 1~8	Undefined
Jog Direction	INVERSE		
Freeze in Preset	OFF		
Park Action	OFF		
Alarm Action	OFF		

Specifications

Model		HTP-T3700		
Video Signal System		NTSC	PAL	
Camera	CCD	1/4" SONY Double Density Interline Transfer CCD		
	Max. Pixels	811(H)×508(V) 410K	795(H)×596(V) 470K	
	Effective Pixels	768(H)×494(V) 380K	752(H)×582(V) 440K	
	Horizontal Res.	550 TV Line(Color), 680 TV Line(B/W)		
	S/N Ratio	50 dB (AGC Off)		
	Zoom	×37 Optical Zoom, ×12 Digital Zoom		
	Focal length	f=3.5~129.5mm (F1.6~3.9)		
	Min. illumination	0.7 Lux/F1.6 (Color), 0.06 Lux/F1.6 (B/W), 50 IRE		
	Day & Night	Auto / Day / Night(ICR)		
	Focus	Auto / Manual / SemiAuto		
	Iris	Auto / Manual		
	Shutter Speed	X256 ~ 1/120000 sec		
	AGC	Low / Middle / High / Off		
	White Balance	Auto / Manual(Red, Blue Gain Adjustable)		
	BLC	WDR / BLC/HLC / Off		
	Flickerless	Selectable		
	SSNR	Low / Middle / High / Off		
Stabilization	On / Off			
Pan/Tilt	Range	Pan 360°(Endless) / Tilt 95°		
	Pan/Tilt Speed	Preset :	360°/sec	
		Manual :	0.05 ~ 360°/sec (proportional to zoom)	
		Swing :	1 ~ 180°/sec	
	Preset	128 Preset (Label, Camera Image Setting)		
	Pattern	4 Pattern, 1200 commands(about 5 minute)/Pattern		
	Swing	8 Swing		
	Group	8 Group (20 action entities per Group)		
Other Functions	Auto Flip, Auto Parking, Power Up Action etc.			
General	Communication	RS-485		
	Protocol	Pelco-D, Pelco-P selectable		
	Alarm I/O	4 Input / 2 Output		
	Privacy Mask Zone	8 Zone		
	OSD	Menu / PTZ information etc.		
	Rated Power**	AC 24V / 1.5A		
	Dimension	Dome :	∅149	
		Housing :	∅206 × 235(H) mm	
	Weight	about 5 Kg		
	Operating Temp.	-30°C ~ 50°C		

* Specifications of this product can be subjected to change without notice.

** Users are obligated to check the voltage and current capacity of rated power carefully.

■ Appearance

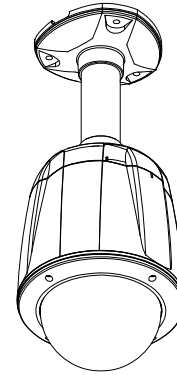

● Ceiling Mount

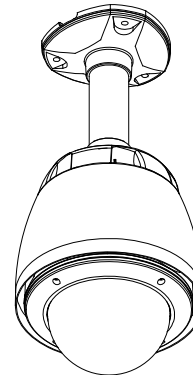

● Ceiling Mount(Sun-)

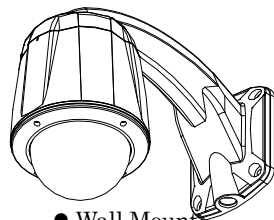

● Wall Mount

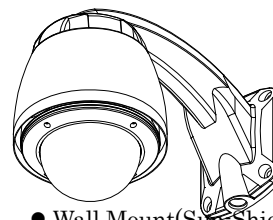

● Wall Mount(Sun Shield)

Dimension

● Main Body

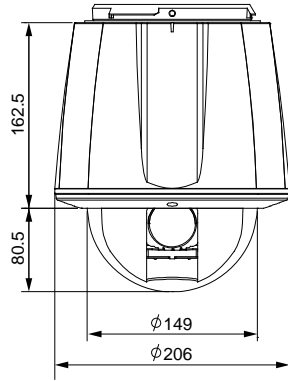

● Ceiling Mount Bracket

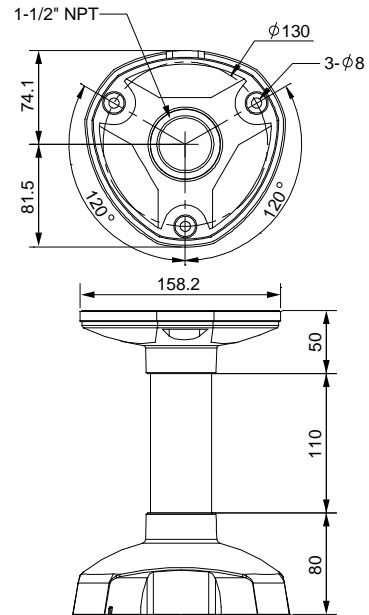

● Main Body (Sun-Shield)

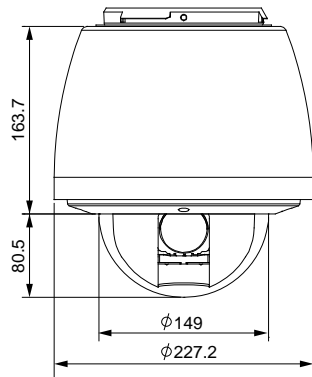

● Wall Mount Bracket

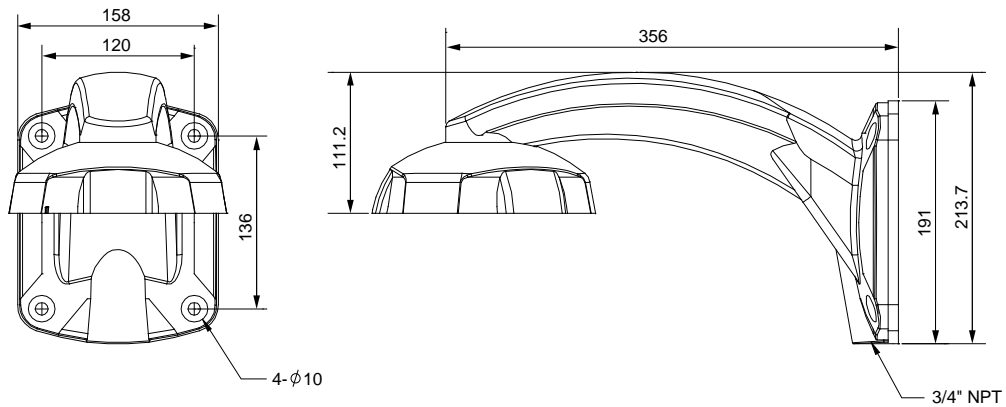

Unit (mm)