

HTC-15 Series Indoor Dome Camera

- ◆ High Resolution 580 TVL
- ◆ Recess with 3-Axis Mount
- ◆ Auto Tracing White Balance
- ◆ 2H Mode of H.V. Aperture Correction
- ◆ Digital Process of Color Matrix
- ◆ Electronic Shutter up to 1/100,000
- ◆ Vari-Focal Auto Iris Lens
- ◆ 24VAC / 12VDC, Dual Voltage

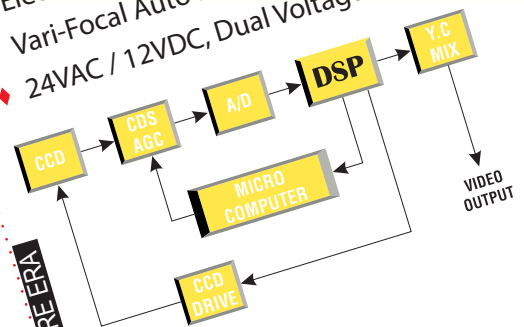

BUILDING A NEW SECURE ERA

Model Number	Day/ Night	LENS	Resolution	Color	Dual Voltage	Sensitivity	IR Sensitivity
HTC-15E-24	Y	3.6mm Fixed	580 TVL	Y	24VAC/ 12VDC	0.08 Lux	850~940nm
HTC-15E28D	Y	2.8~10mm	580 TVL	Y	24VAC/ 12VDC	0.08 Lux	850~940nm
HTC-15E28M	Y	Manual Iris	580 TVL	Y	24VAC/ 12VDC	0.08 Lux	850~940nm
HTC-15A-24	Y	3.6mm Fixed	400 TVL	Y	24VAC/ 12VDC	1 Lux	850~940nm
HTC-15A28D	Y	2.8~10mm	400 TVL	Y	24VAC/ 12VDC	1 Lux	850~940nm
HTC-15A28M	Y	Manual Iris	400 TVL	Y	24VAC/ 12VDC	1 Lux	850~940nm

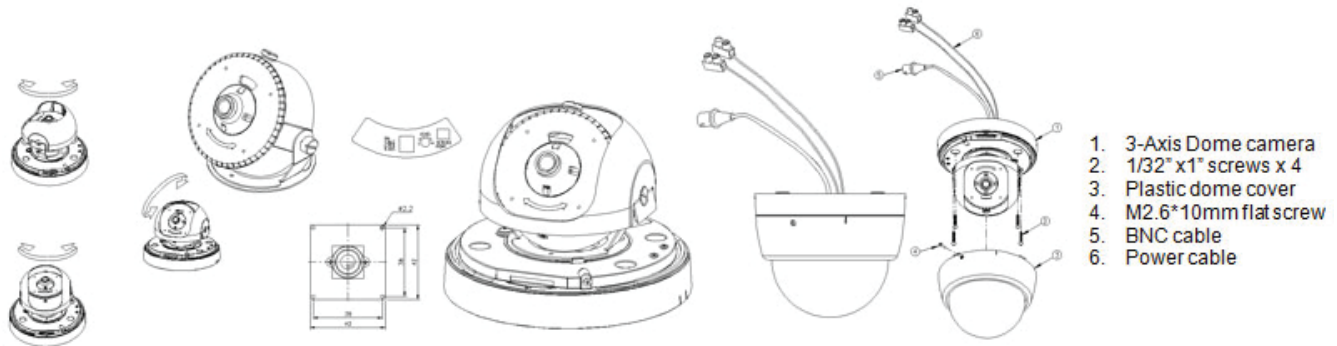

SPECIFICATIONS

ITEM NO	HTC-15E-24	HTC-15E28D	HTC-15E28M	HTC-15A-24	HTC-15A28D	HTC-15A28M
PICK UP DEVICE	1/3" Sony CCD					
PIXEL (TOTAL)	811H x 508V					
PIXEL (EFFECTIVE)	768H x 494V					
OPTICS	3.6mm Fixed	2.8~10mm	2.8~10mm Manual	3.6mm Fixed	2.8~10mm	2.8~10mm Manual
RESOLUTION	580 TVL	580 TVL	580 TVL	400 TVL	400 TVL	400 TVL
H. SYNC FREQUENCY	NTSC 15.734 KHz / PAL 15.625 KHz					
V. SYNC FREQUENCY	NTSC 59.95 Hz / PAL 50 Hz					
SCANNING SYSTEM	2:1 INTERLACE					
SENSITIVITY	0.08 LUX			1 LUX		
SYNCHRONIZATION	INTERNAL					
S/N RATIO	MORE THAN 48 dB (AGC OFF)					
BACK LIGHT COMPENSATION	ON / OFF SWITCH					
ELECTRONIC SHUTTER	ON / OFF SWITCH; RANGE 1/50 (1/60) UP TO 1/100,000					
GAIN CONTROL	ON / OFF SWITCH					
GAMMA	0.45					
VIDEO OUTPUT	1 Vpp, 75 Ohms					
POWER SUPPLY	DC12V / AC 24V, DUAL POWER					
POWER CONSUMPTION	DC 200 mA, AC 2.4w					
WEIGHT	700gr					
DIMENSIONS	Ø5.5 * H4.5inch					
STORAGE TEMPERATURE	-30 TO +60C					
OPERATION TEMPERATURE	-10 TO +45C					